

ACADEMY

HOBBY MODEL KITS

Clipper ship Cutty Sark

쾌속 범선 커티삭

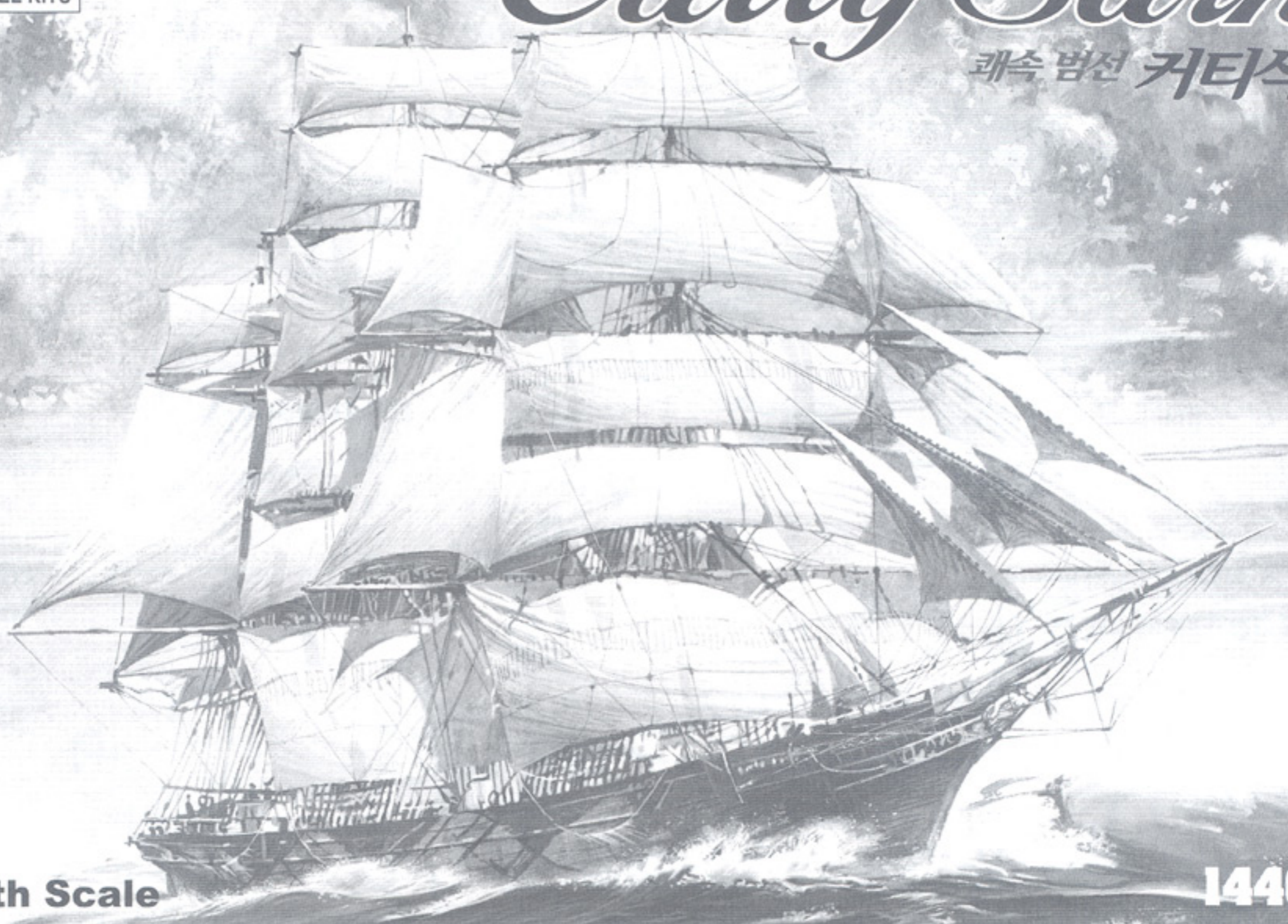

1/150th Scale

14403

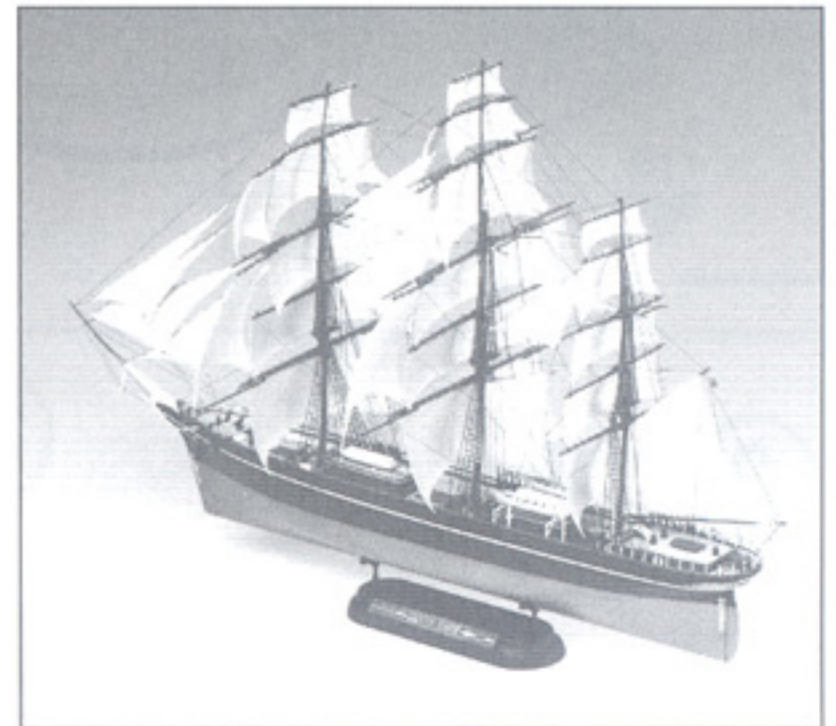
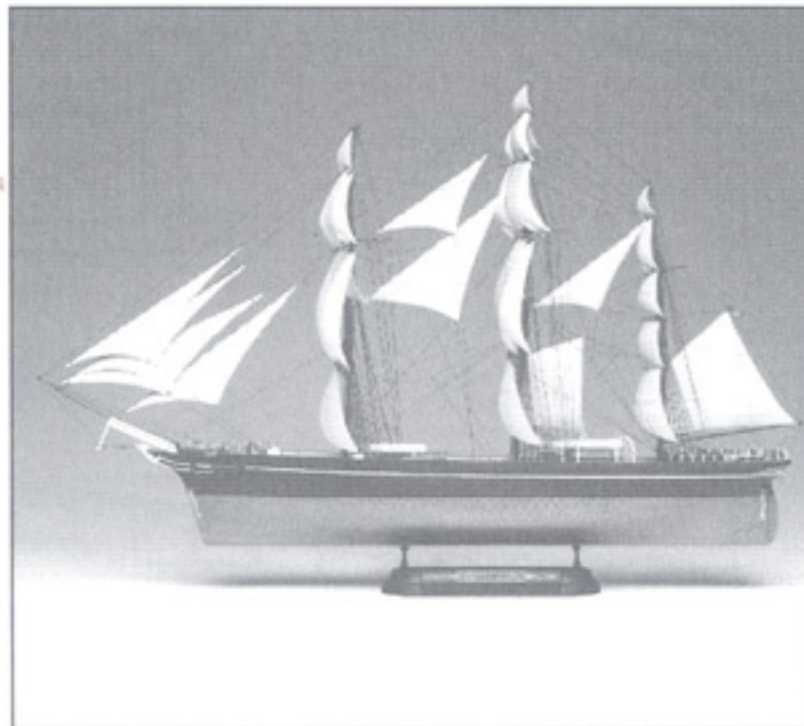
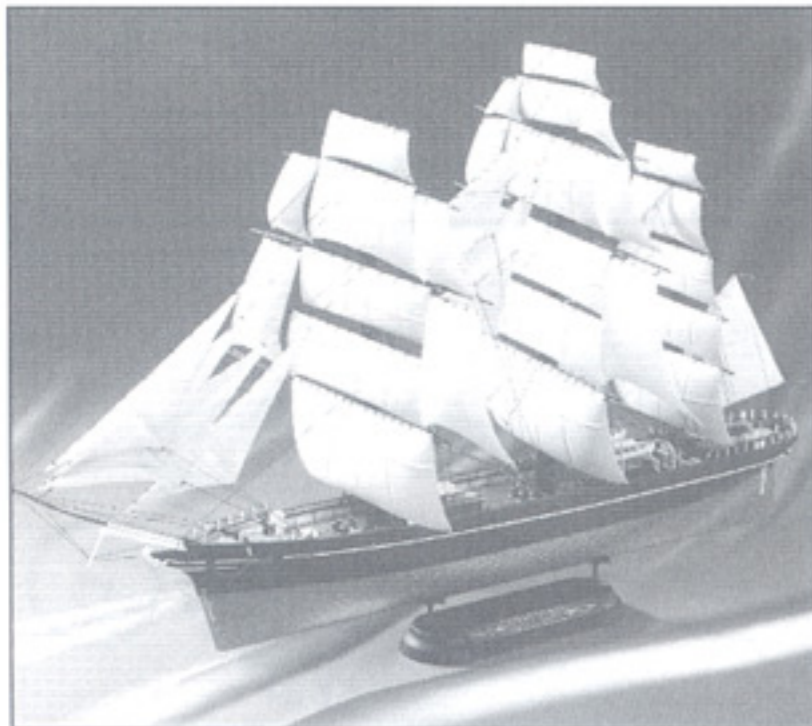

The Cutty Sark is one of the most famous of the old clipper ships; fast sailing vessels used for transporting goods between the Orient and western during the nineteenth century. The Cutty Sark is the sole survivor of these great ships and is now a museum in London. A clipper had a sharp, narrow hull designed for slicing through the high seas, and could carry as 28 sails on its tall masts. Because they were the fastest ships on the seas their owners could charge a premium price for delivering their cargo of tea, wool and gold in the shortest possible time.

커티삭은 1869년 11월 23일에 진수식을 가졌다. 하지만 그 해는 수에즈운하의 공개가 선언된 해이기도 했다. 수에즈운하의 개통은, 그동안 희망봉을 돌아 긴 항해를 해 왔던 범선들에게는, 범선의 시대가 끝났음을 알리는 것이기도 했다. 이런 의미에서 커티삭은 범선 황금기의 마지막을 장식하는 배라고 말할 수 있다. 커티삭은 1925년 전 매되는 운명이 되었으나 1936년에는 팀즈항해학교의 연습선으로 활약 하기도 하였으며, 2차 대전후 국립해양박물관에 기증되어 현재까지 해양사의 좋은자료로서 활용되고 있다.

<READ THIS BEFORE YOU BEGIN>

- Study the instructions before assembling.
- Check the fit of each piece before cementing into place.
- Do not use too much cement to join parts.
- Never use cement or paint near open flame.
- Open a window or make area well ventilated when cement or paint is in use.
- Tear up and throw away the empty plastic bags to avoid danger of suffocation for little children.

<ALLGEMEINE HINWEISE>

- Die Anordnung der Bauteile ist aus den Zeichnungen der Anleitung ersichtlich.
- Die Teile vor dem Verkleben ungleichmäßig zusammenhalten, um ihren paßsitz zu prüfen.
- Klebstoff nicht zu dick auftragen.
- Klebstoff und Farben niemals in der Nähe einer Flamme verwenden.
- Während der Bemalung mit Spritzpistole oder Pinsel für frische Luftzufuhr, z.B. Öffnen des Fensters, sorgen.
- Bausatz von kleinen Kindern fernhalten. Verhüten Sie, daß Kinder irgendwelche Bauteile in den Mund nehmen oder Plastklüten über den Kopf ziehen.



<LISEZ CE QUI SUIT AVANT DE COMMENCER LE MONTAGE>

- Etudier les schémas d'assemblage.
- Contrôler que chaque pièce soit bien conforme avant de la coller à sa place.
- N'utilisez pas trop de colle pour réunir les pièces.
- Ne faites jamais manipuler la colle ou peinture à proximité d'une flamme.
- Aérez soigneusement la pièce où vous peignez(ouvrez la fenêtre).
- Après avoir sorti les pièces du sac en plastique, déchirer le sac afin d'éviter que les enfants ne le mettent sur la tête et ne s'étouffent.

<組み立てる前に>

- 組み立てる前に説明書をお読み下さい。
- 部品をランナーから切りはなす時は模型用ニッパーとカッターを使用します。
- 接着剤を少しなめに使うことがきれいに仕上げるコツです。
- 組み立て後の部品やビニール袋は小さな子供の手の届かない安全な所に保管して下さい。
- 接着剤や塗料を使用する時はときどき窓を開けて換気に気をつけましょう。
- 接着する前に部品を合わせて確かめます。

■ 조립하기 전에

- 부품을 조립하기 전에 설명서를 잘 읽어본 후 조립한다.
- 부품들 자를 때에는 칼이나 니퍼로 깨끗이 잘라준다.
- 점착제를 사용할 곳과 사용하지 않는 곳에 주의하고 너무 많이 비르지 않도록 한다.
- 접착하기 전에 부품을 맞추어 확인한 후 조립한다.
- 에니멜 페인트나 점착제를 사용할 때는 창문을 열어 환기를 시키고 회기를 멀리한다.
- 사용 후 남은 부품은 어린 아이들의 손에 닿지 않도록 잘 처리한다.

1 

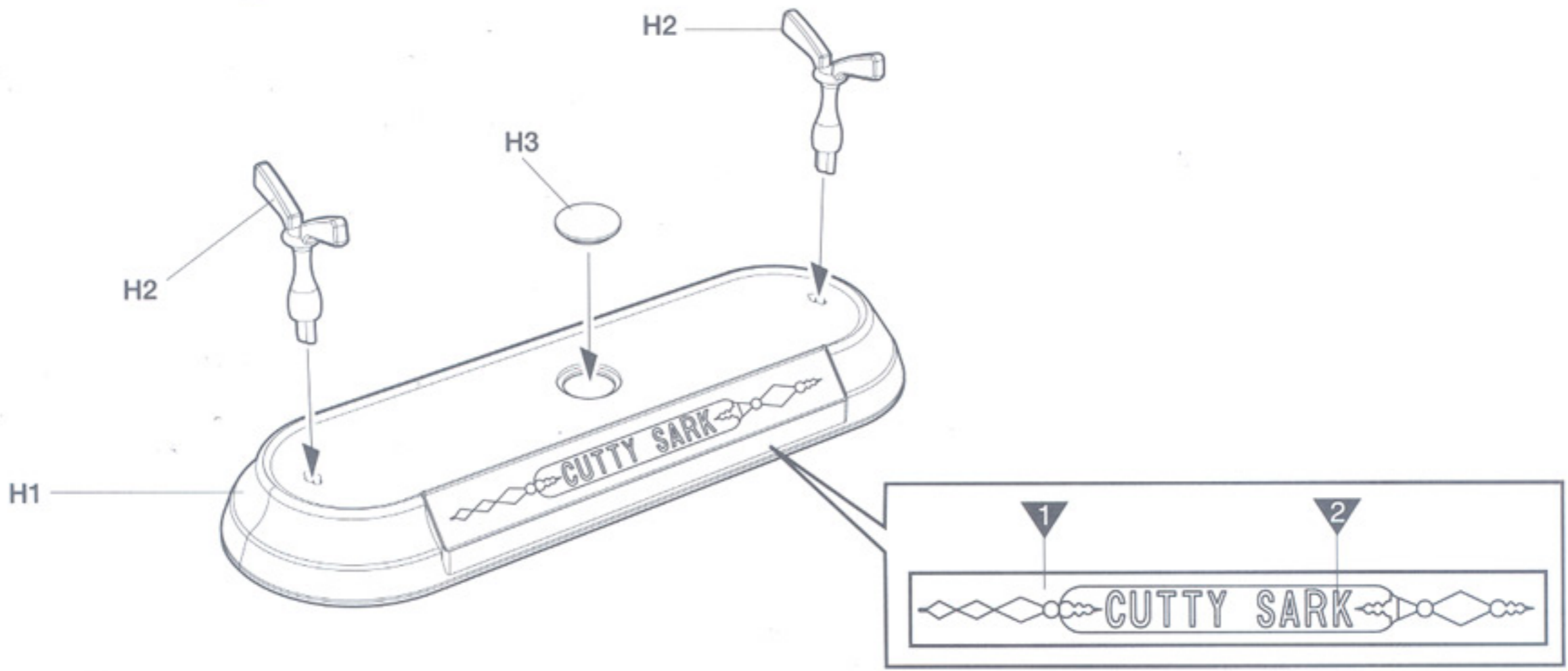
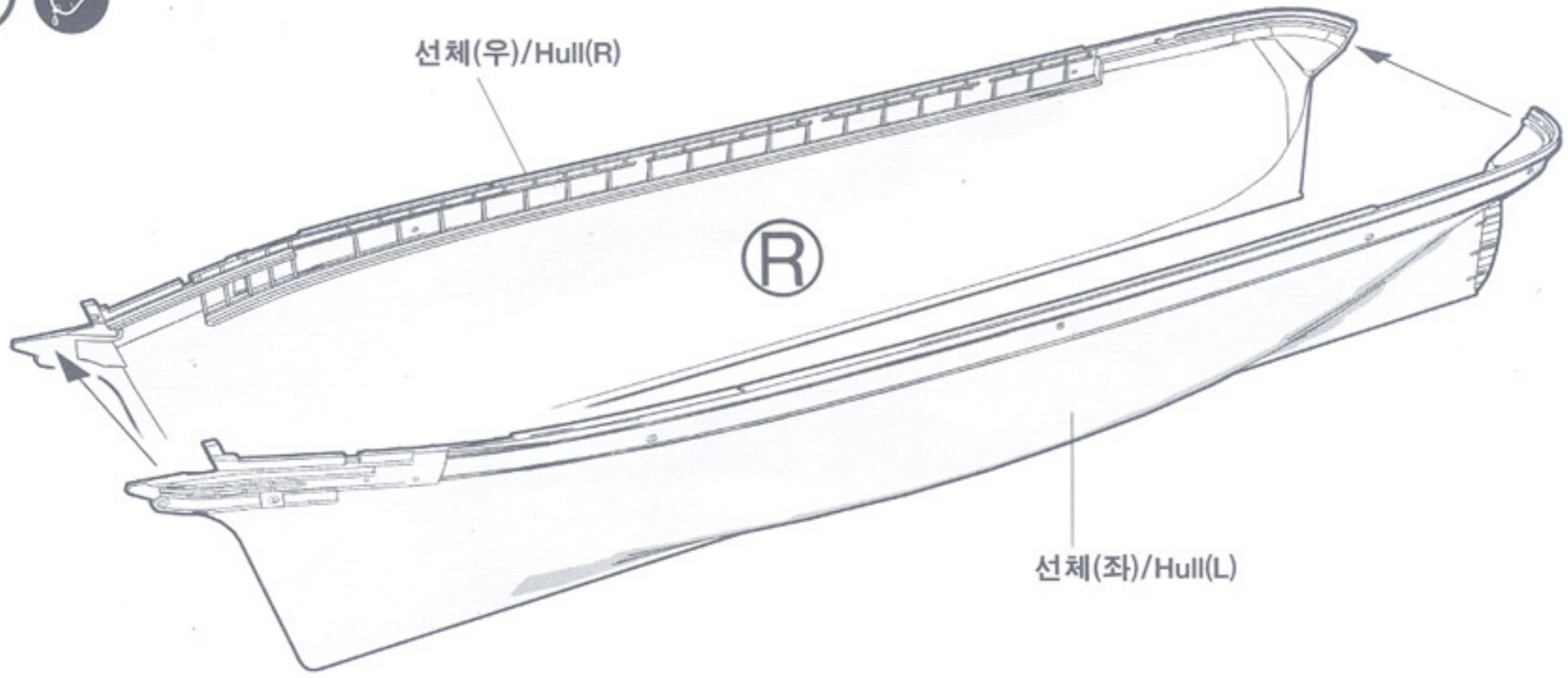

2

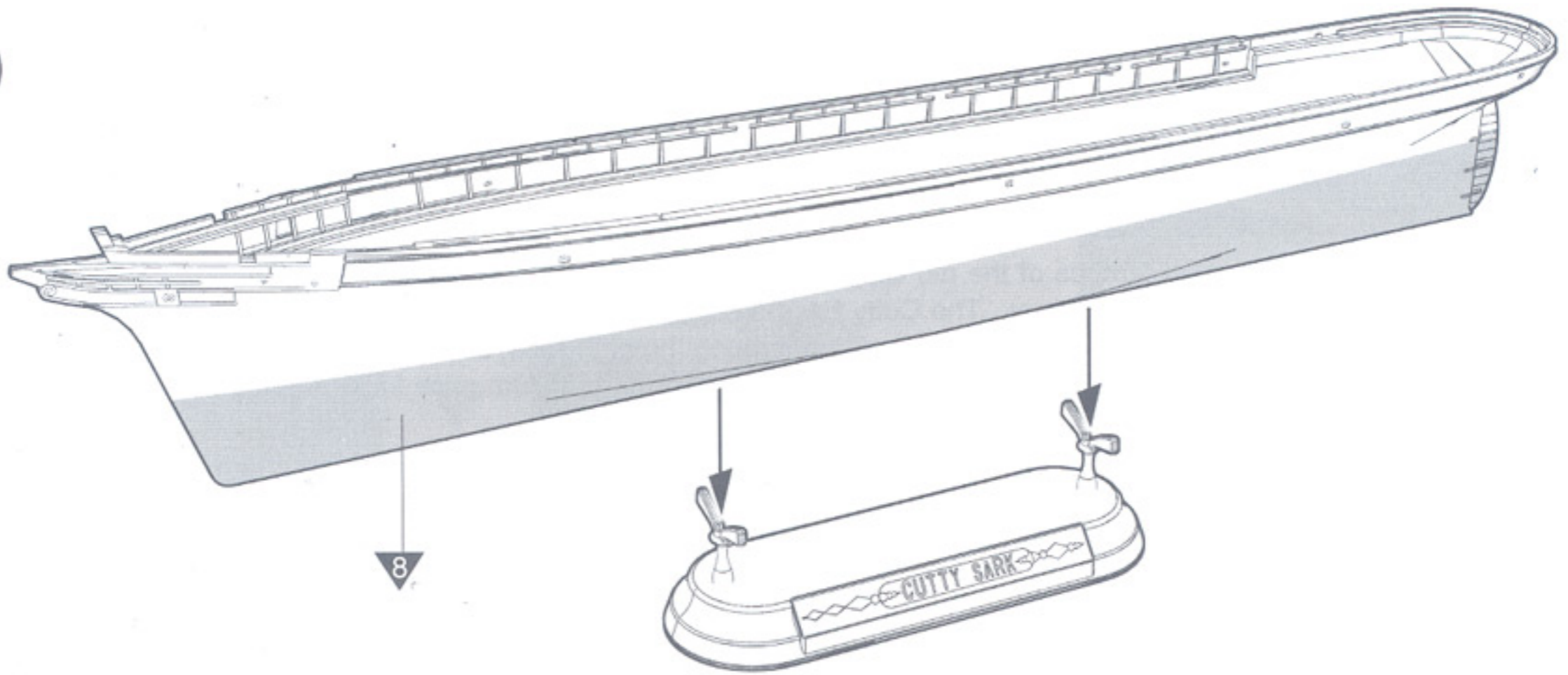

- | | | | | | |
|---|--|---|--|---|--|
|  <p>접착한다.
Cement parts
Coller
Kleben
Pegar
Incollare
Colar
Kleven</p> |  <p>접착하지 않는다.
Do not cement
Ne pas coller
Nicht kleben
No pegar
Non incollare
Nao colar
Niet kleven</p> |  <p>3
수반을 조심한다.
Repeat operation
Répéter l'opération
Vorgang wiederholen
Repitir la operacion
Ripetere
Repitir a operaçao
Herhalen</p> |  <p>전사지를 붙인다.
Decals
Décalcomanies
Abziehbild</p> |  <p>9
무게수를 넣는다.
Add weight
Lester
Gewicht</p> |  <p>구멍이나 틈을 막아준다.
Use filler
Masquer
Schließen</p> |
|  <p>잘라낸다.
Cut away
Couper
Schneiden
Cortare
Tagliare
Cortar
Snijden</p> |  <p>선택한다.
Optional parts
Choix
Auswahlmöglichkeit
Eleccion
Scelta
Opcao
Keuze</p> |  <p>반대쪽도 조심한다.
Repeat for opposite side
Répétition de la page
Wiederholung für gegenüberlie-
gende Seite</p> |  <p>구멍을 뚫어준다.
Make hole
Faire un trou
Öffnen</p> |  <p>주의한다.
Be careful
Faire attention
Hier Vorsicht</p> |  <p>색칠 및 전사지 붙이기 번호
Painting scheme number
Numeros de la liste de peintures
Lackierschemanummer</p> |

3 

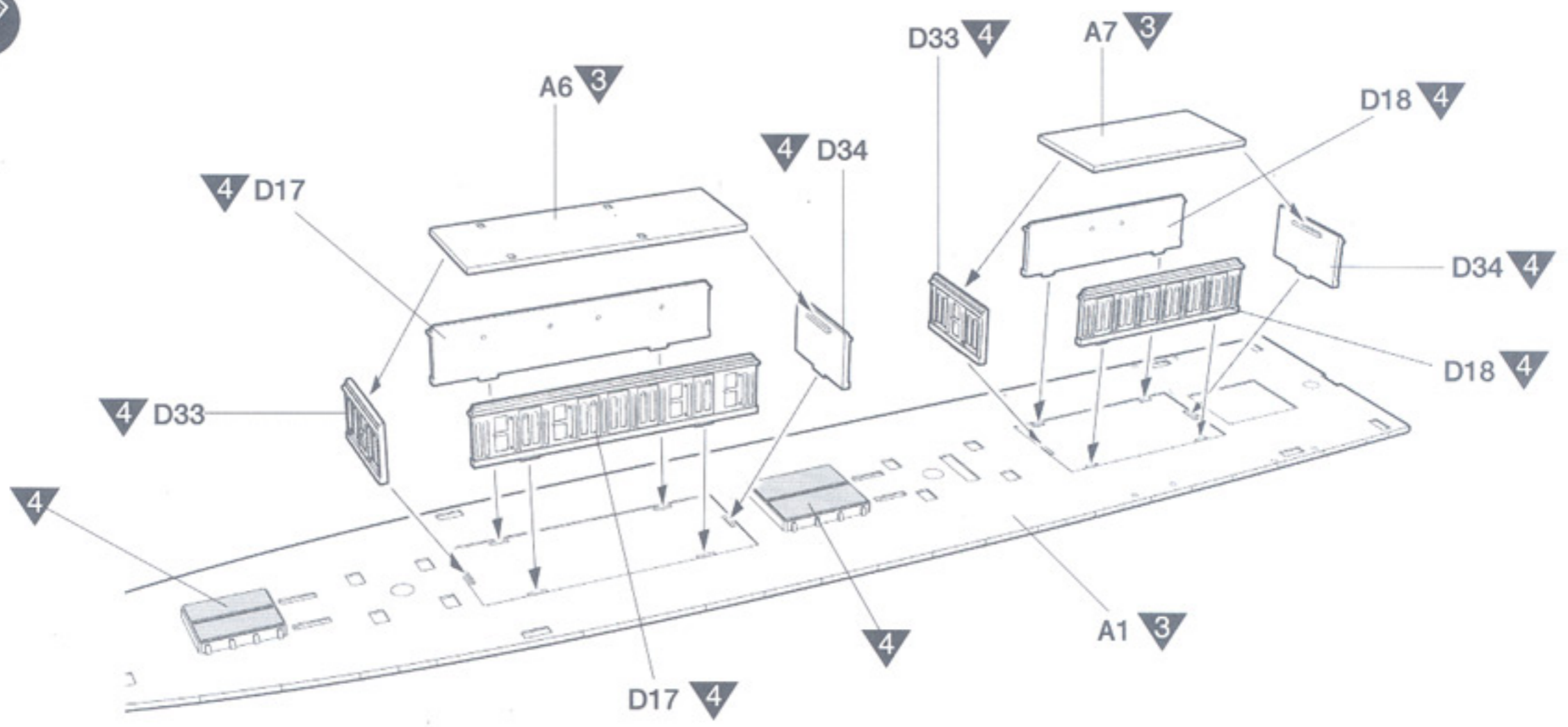

4 

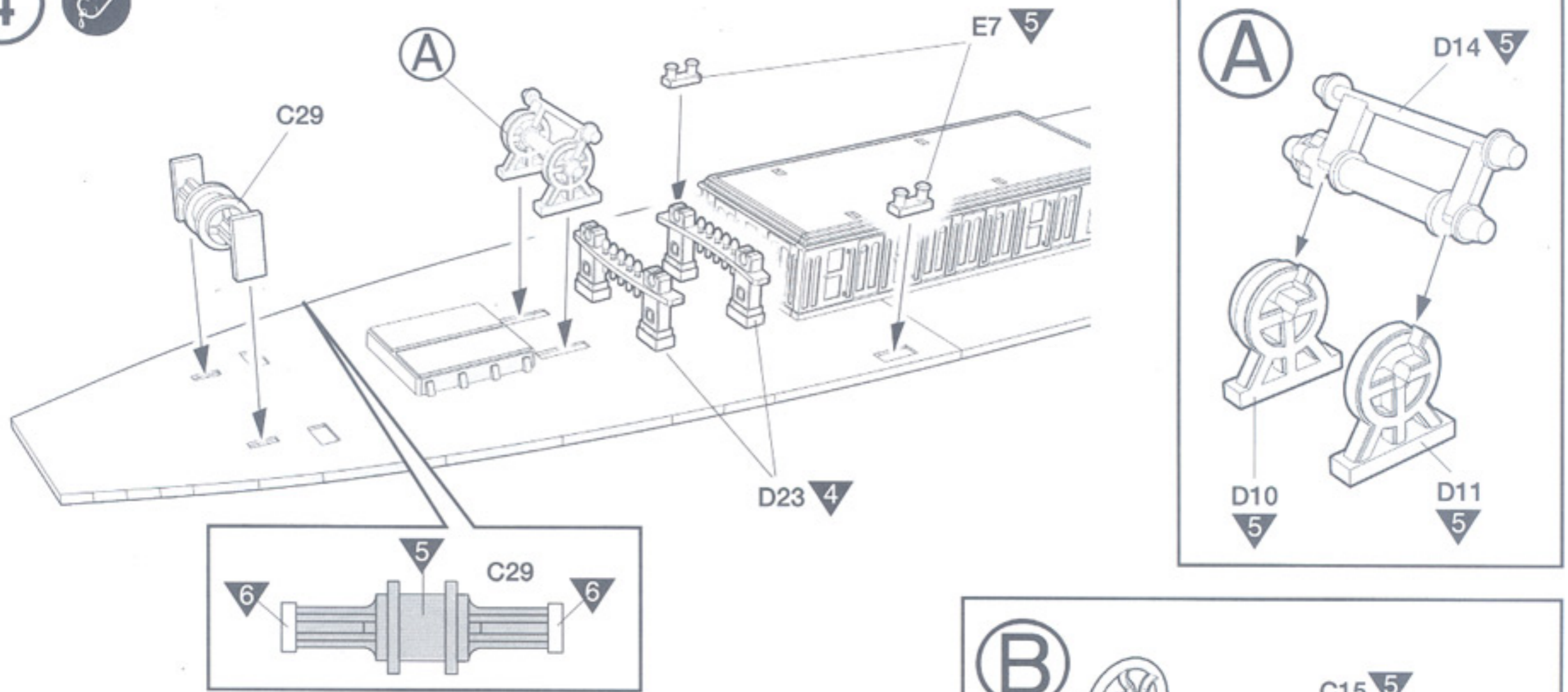

5 

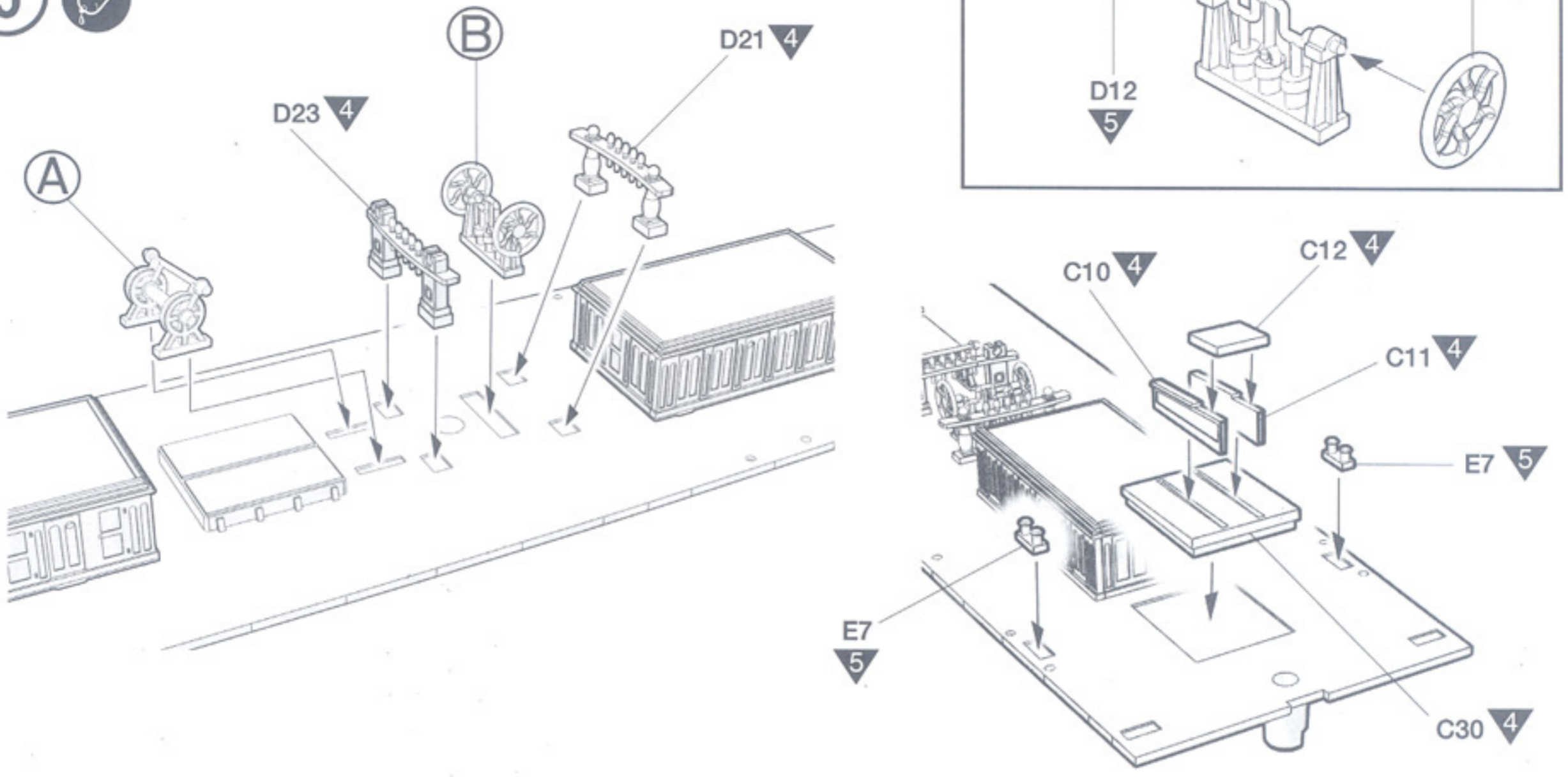

6

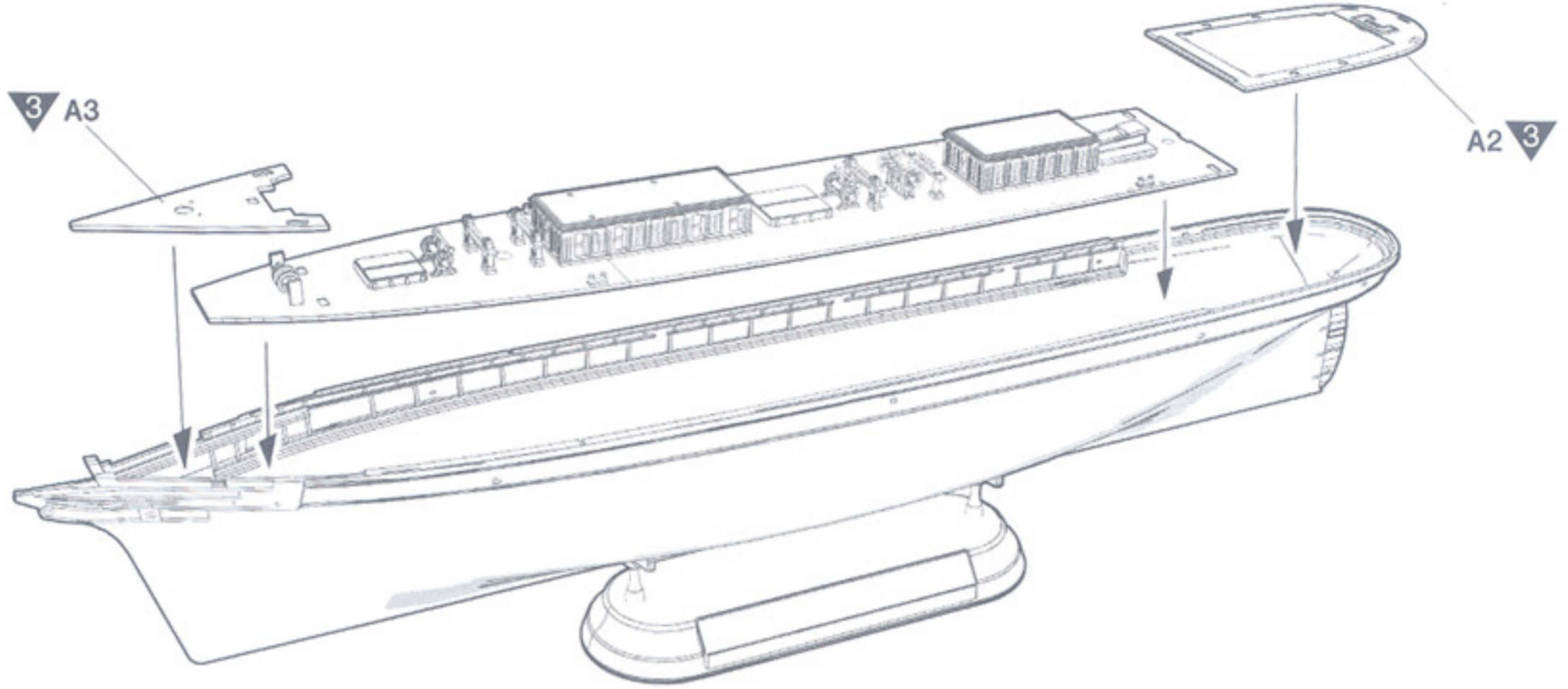

7

※ () is opposite number.
()는 반대쪽 번호 입니다.

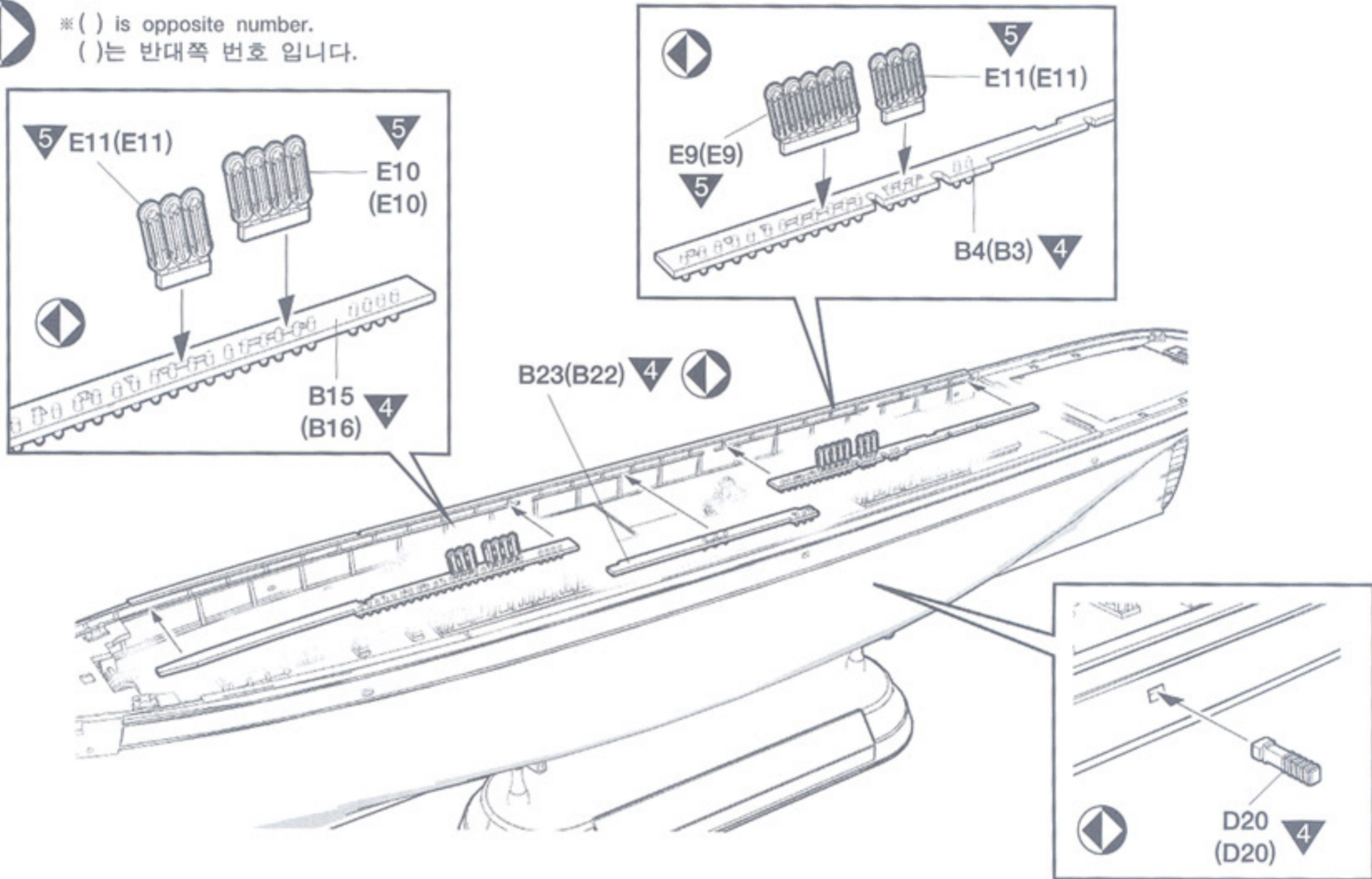

8

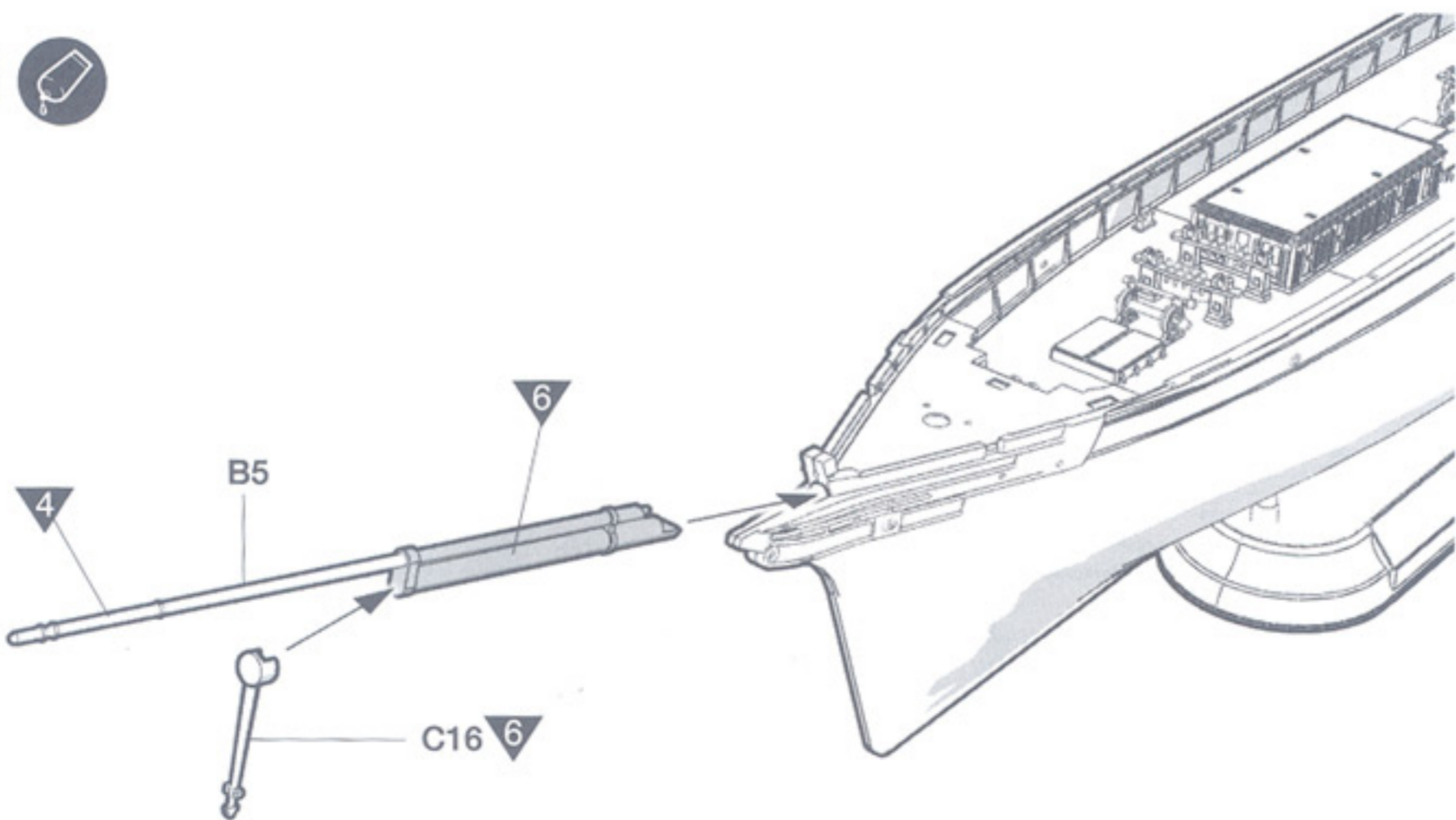

9

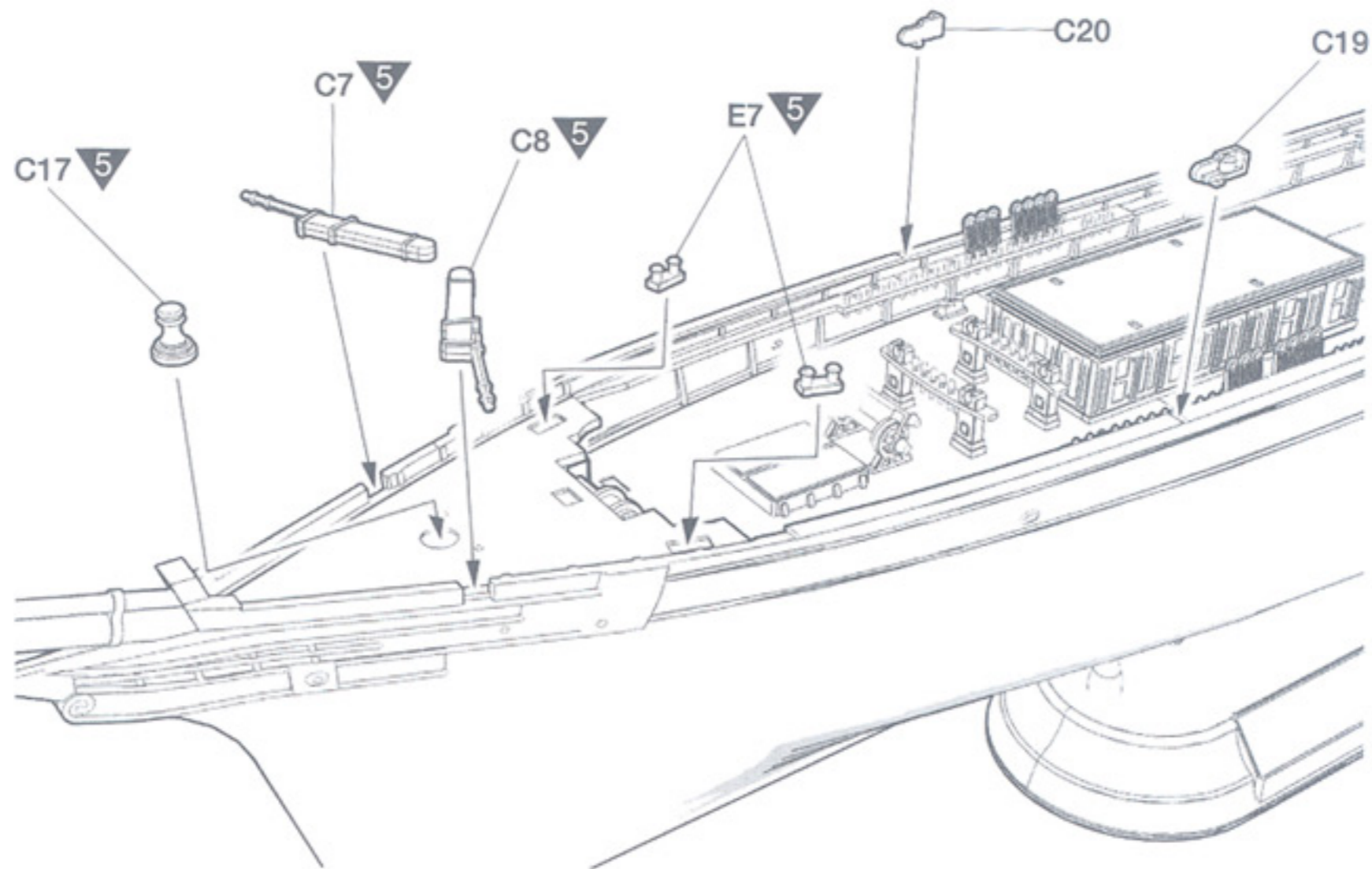

10

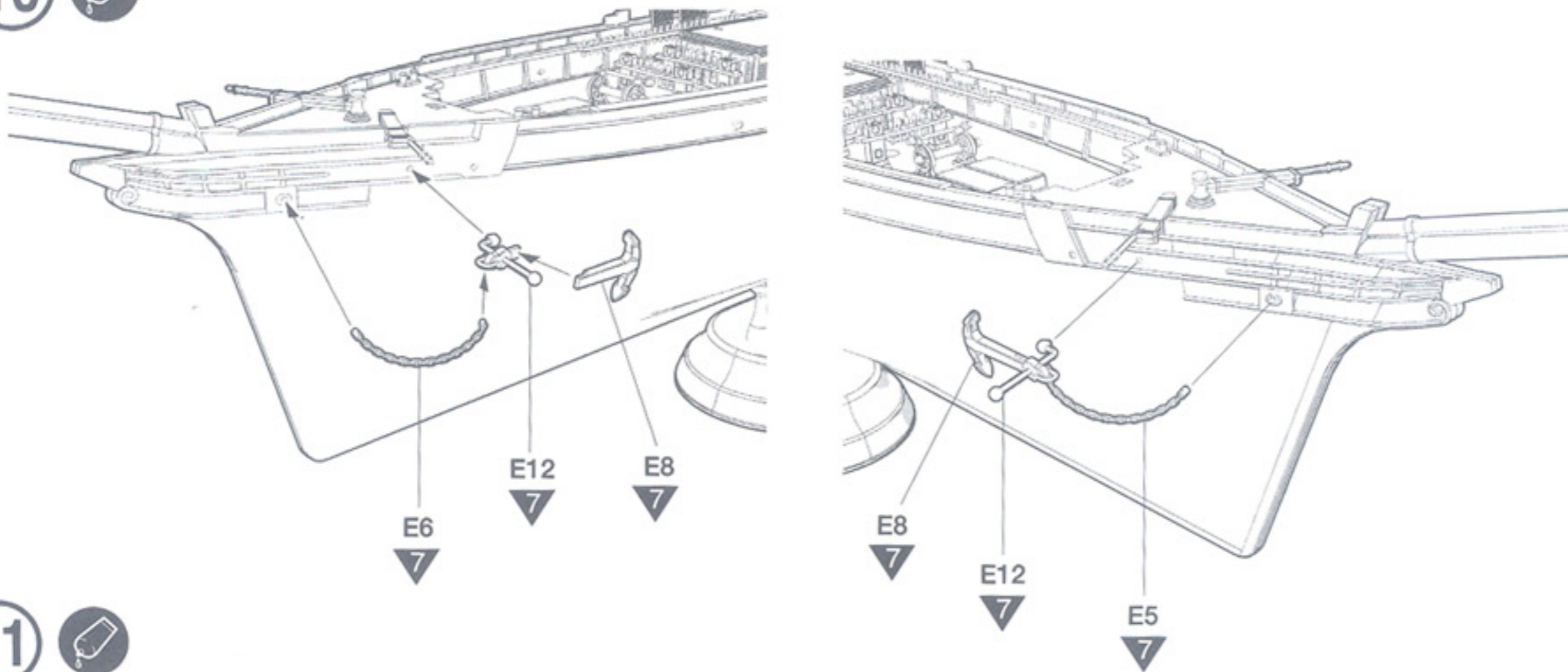

11

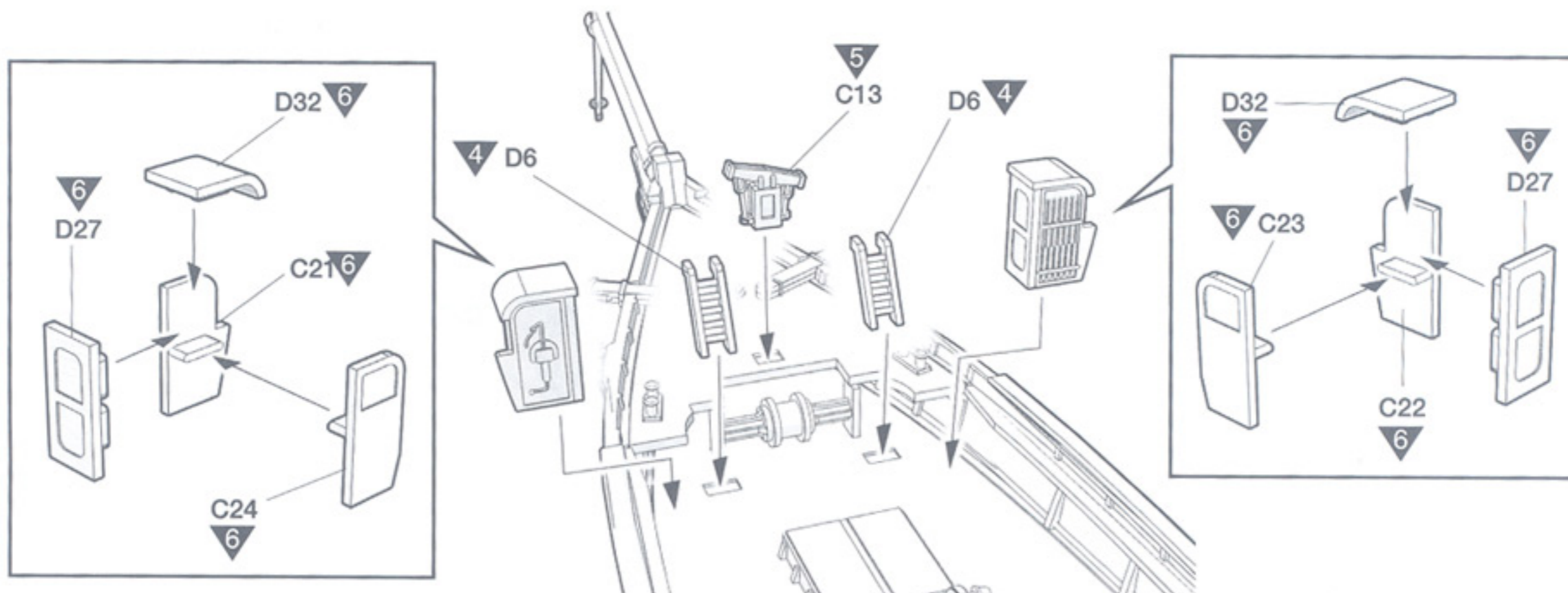

12 

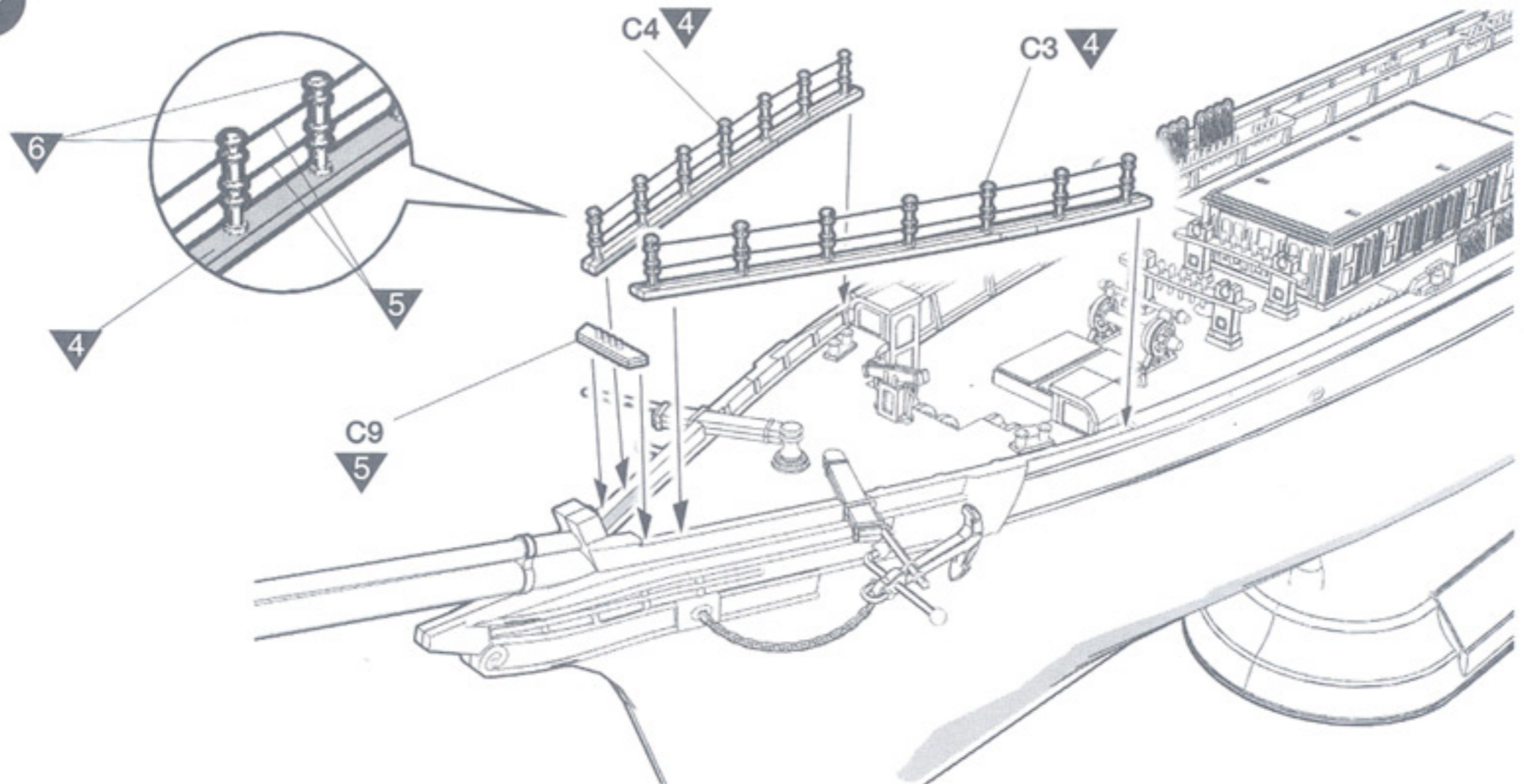

13 

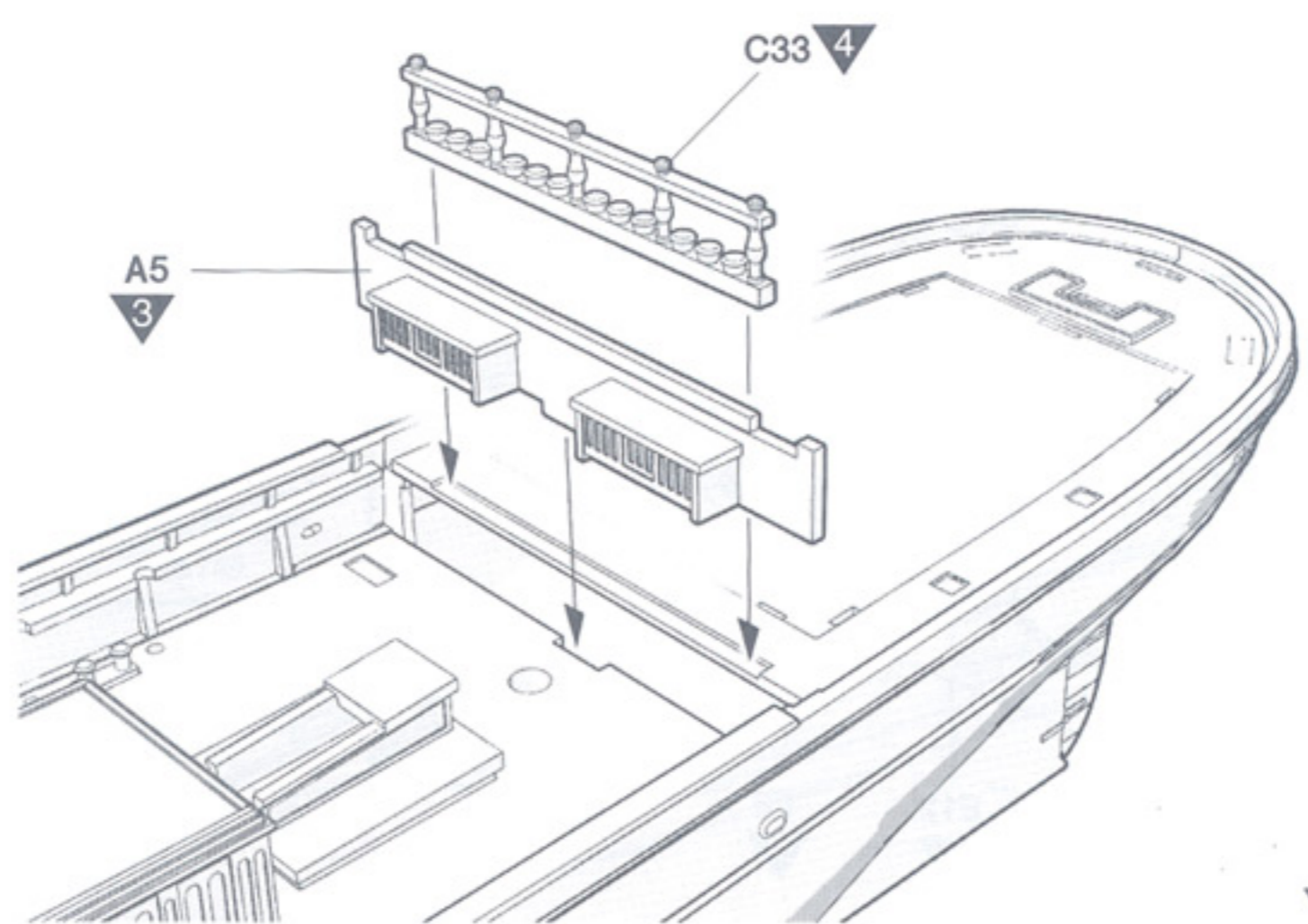

14 

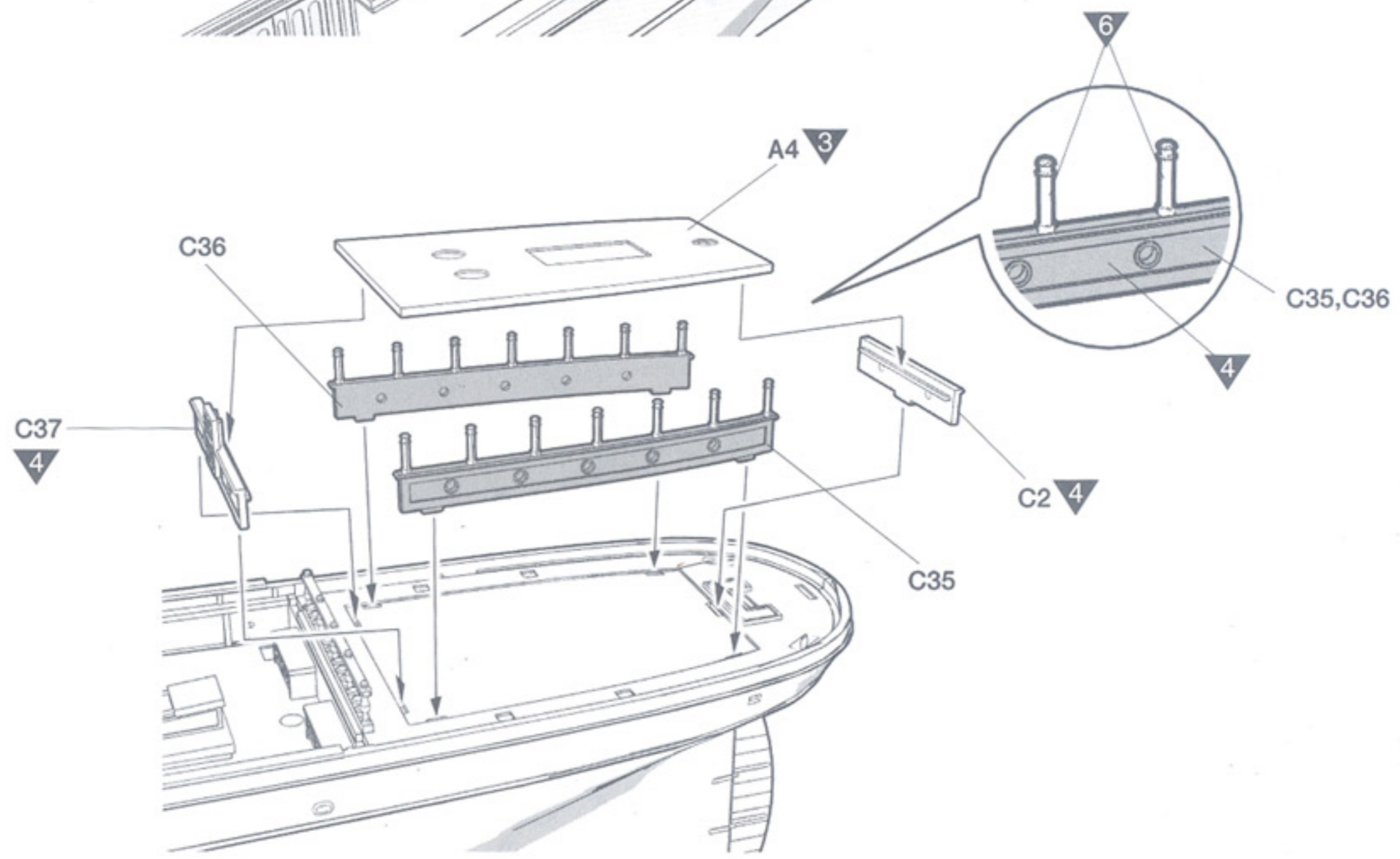

15 

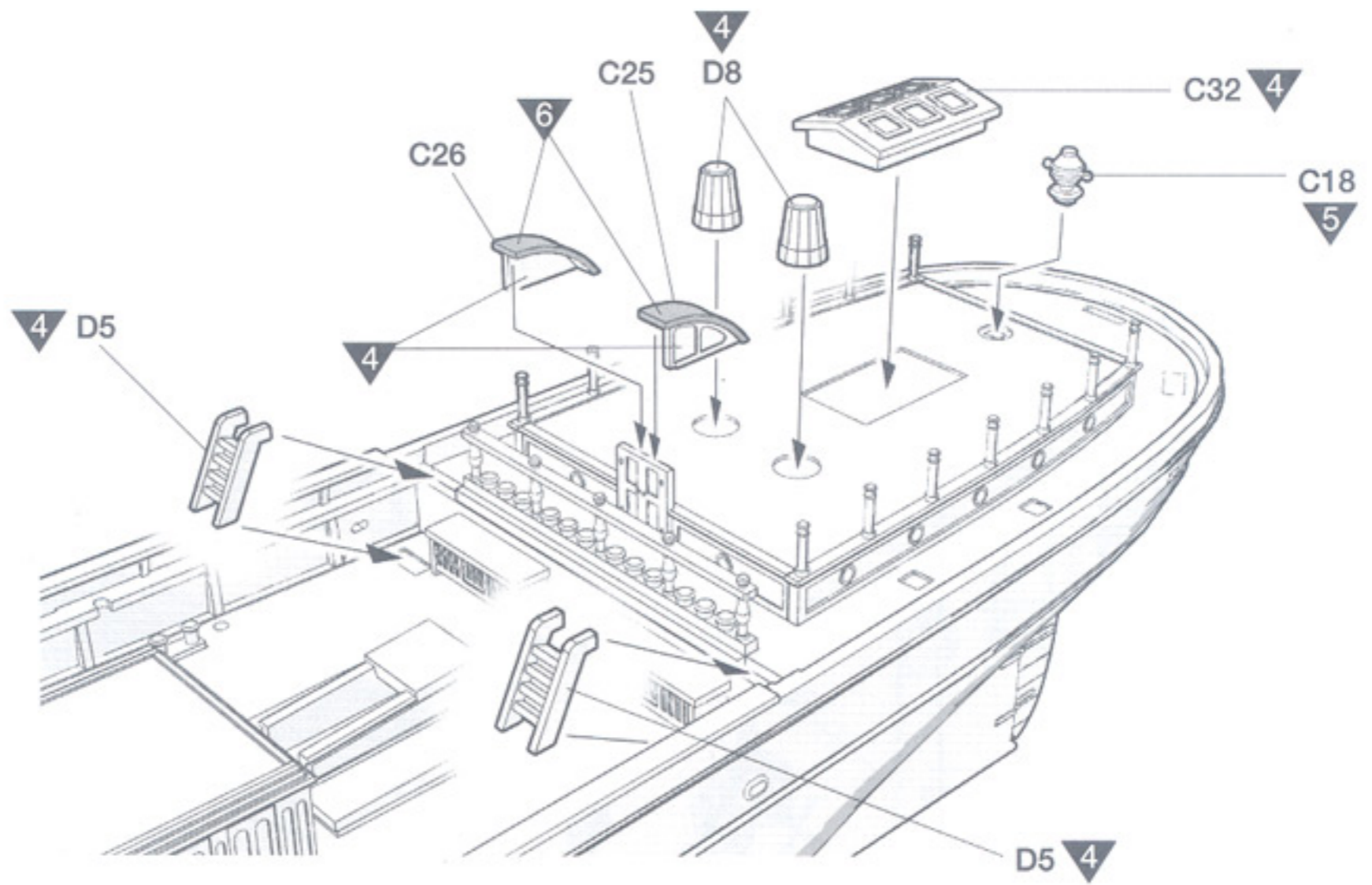

16 

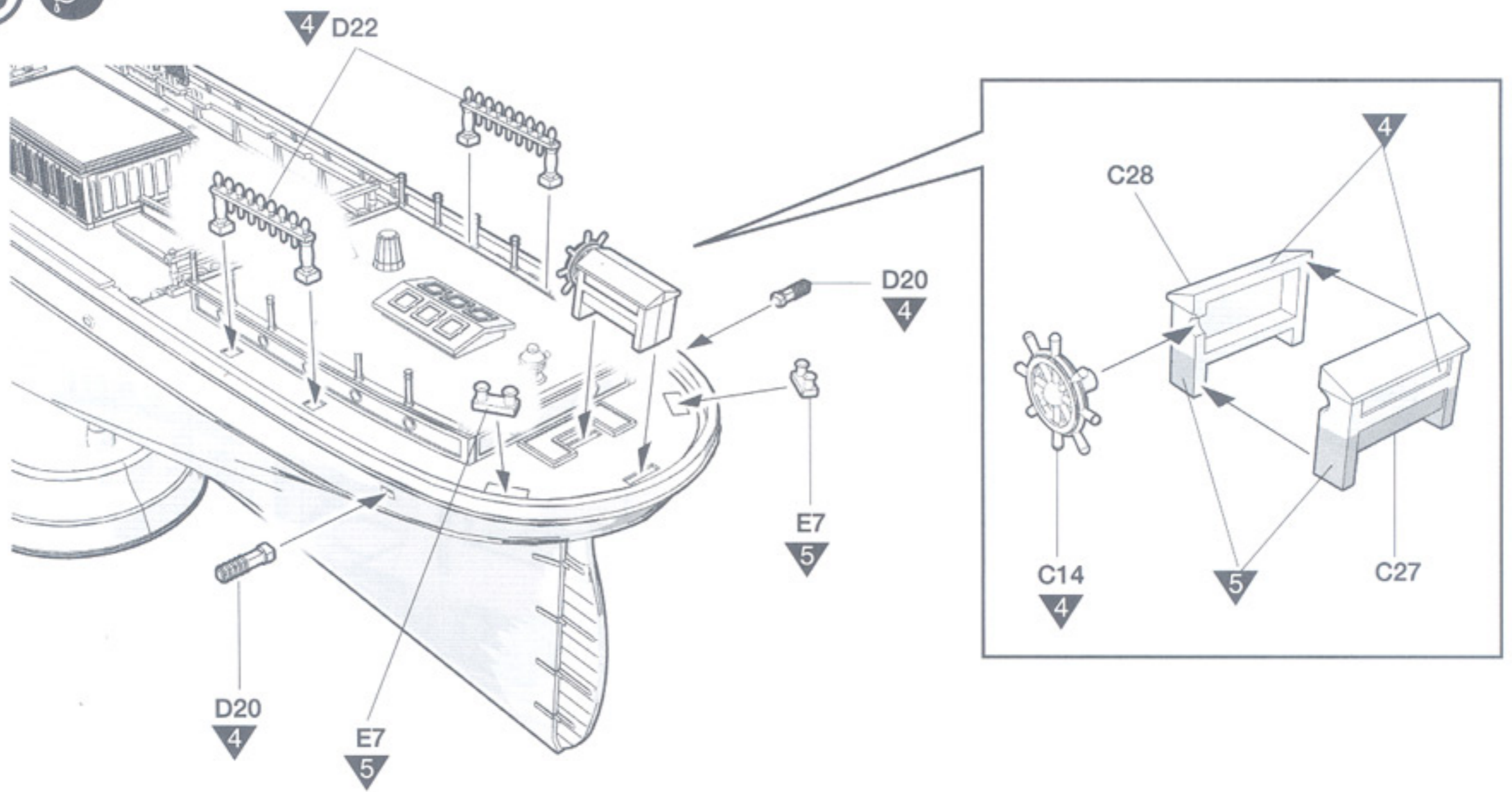

17 

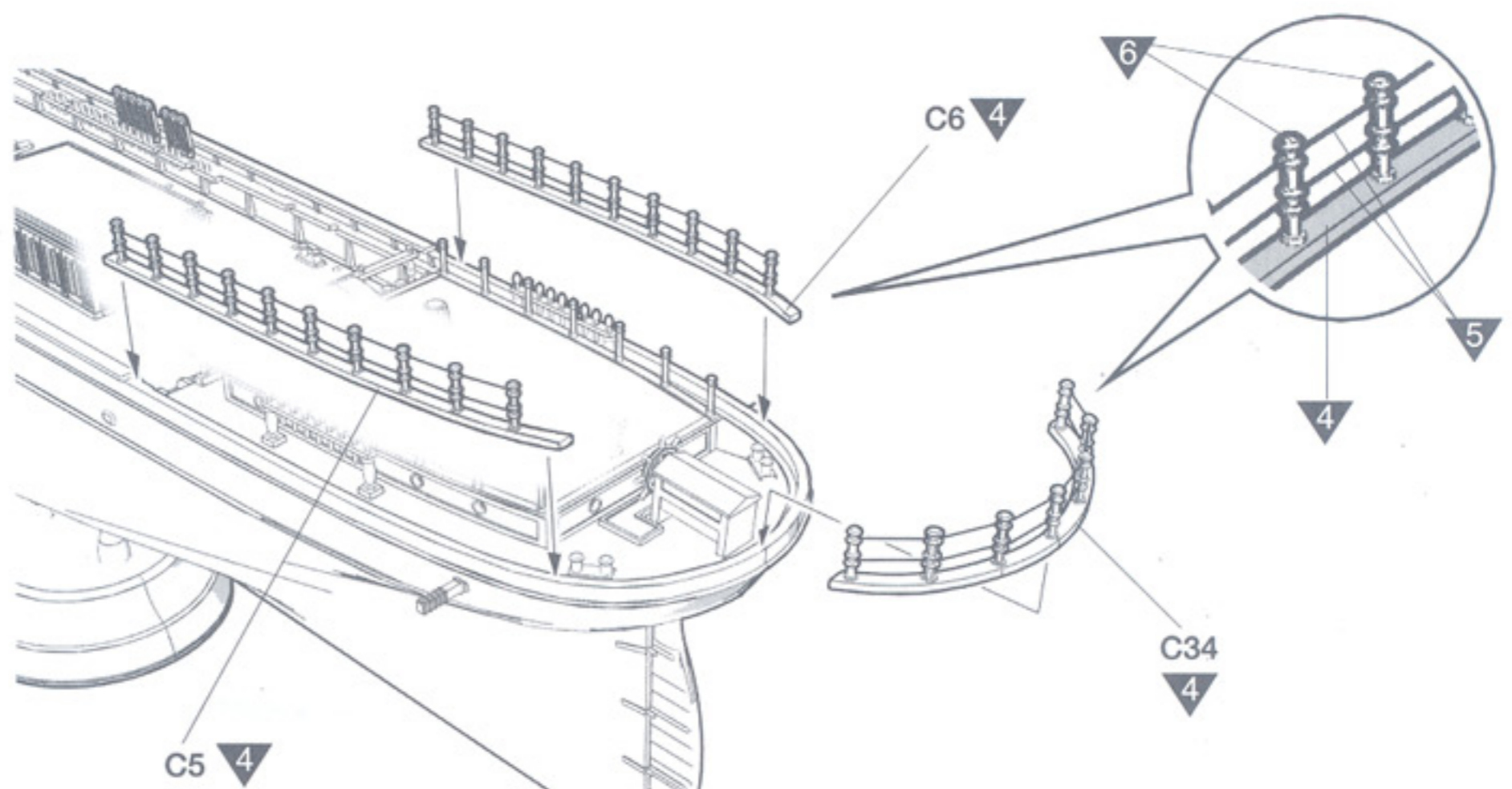

18

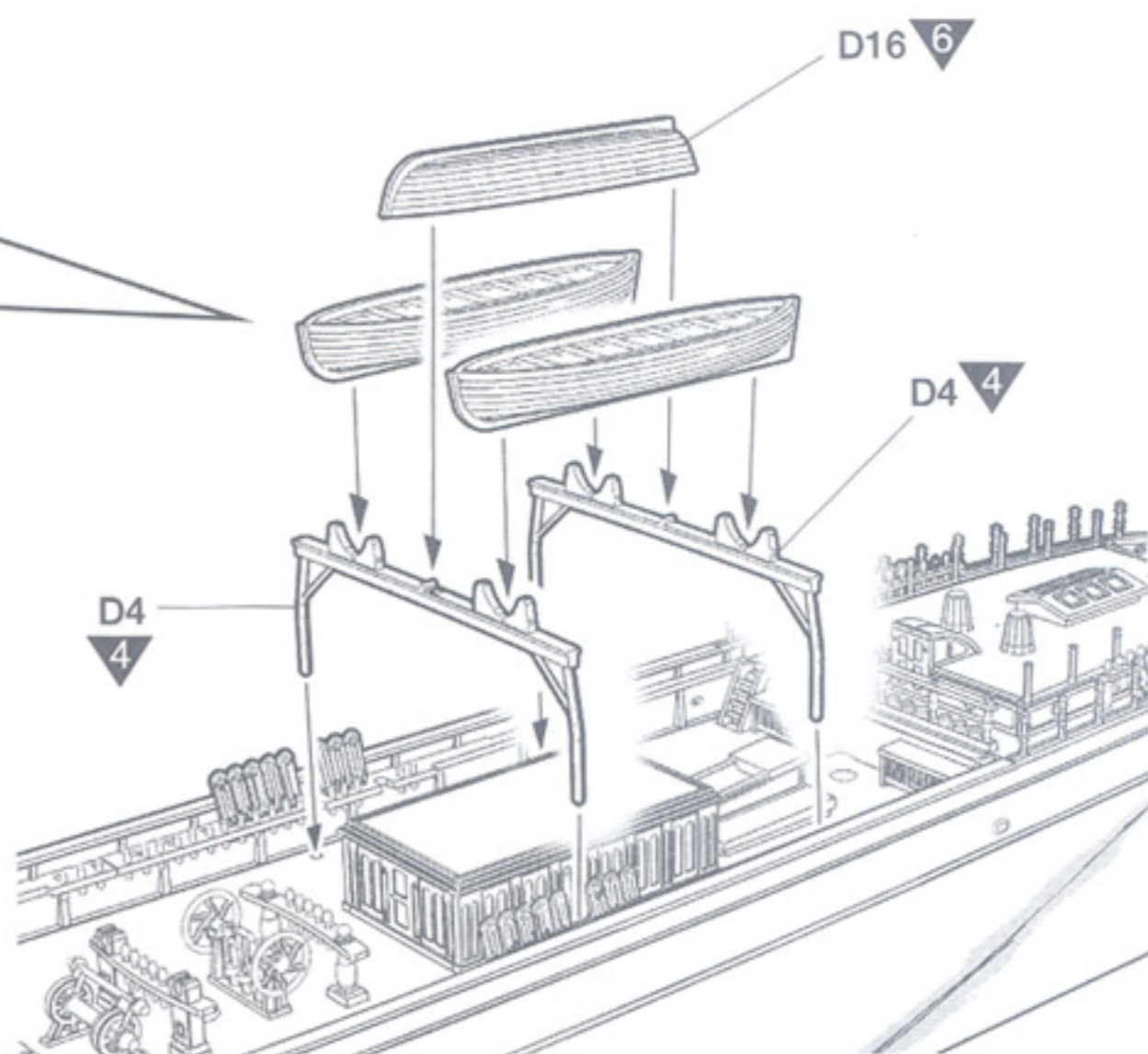
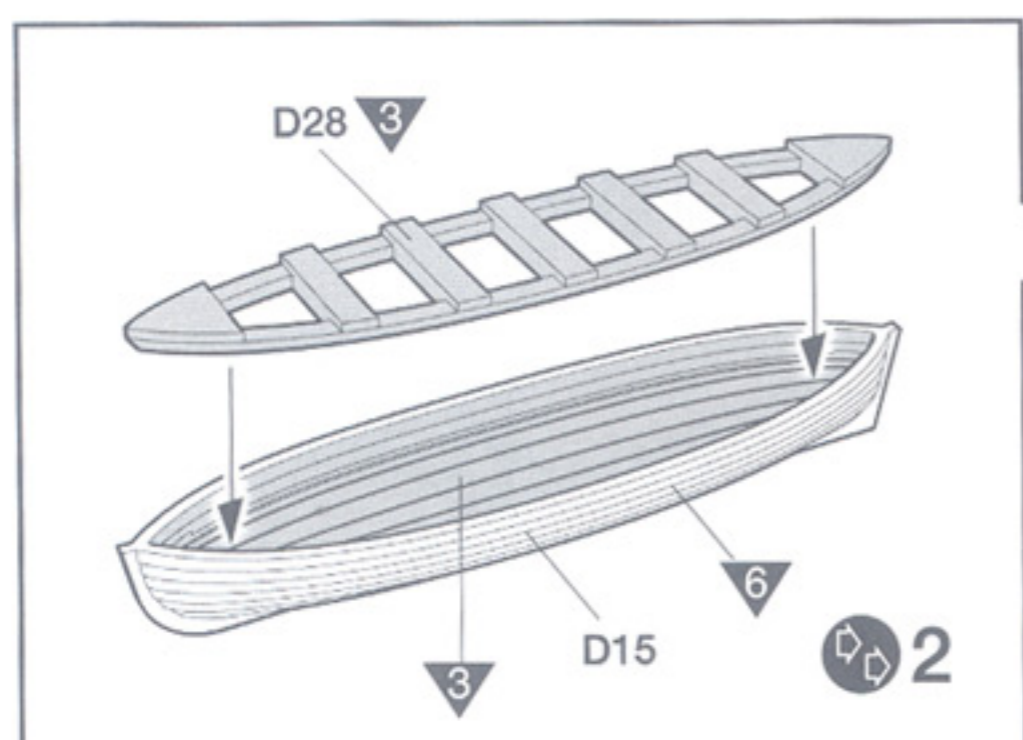
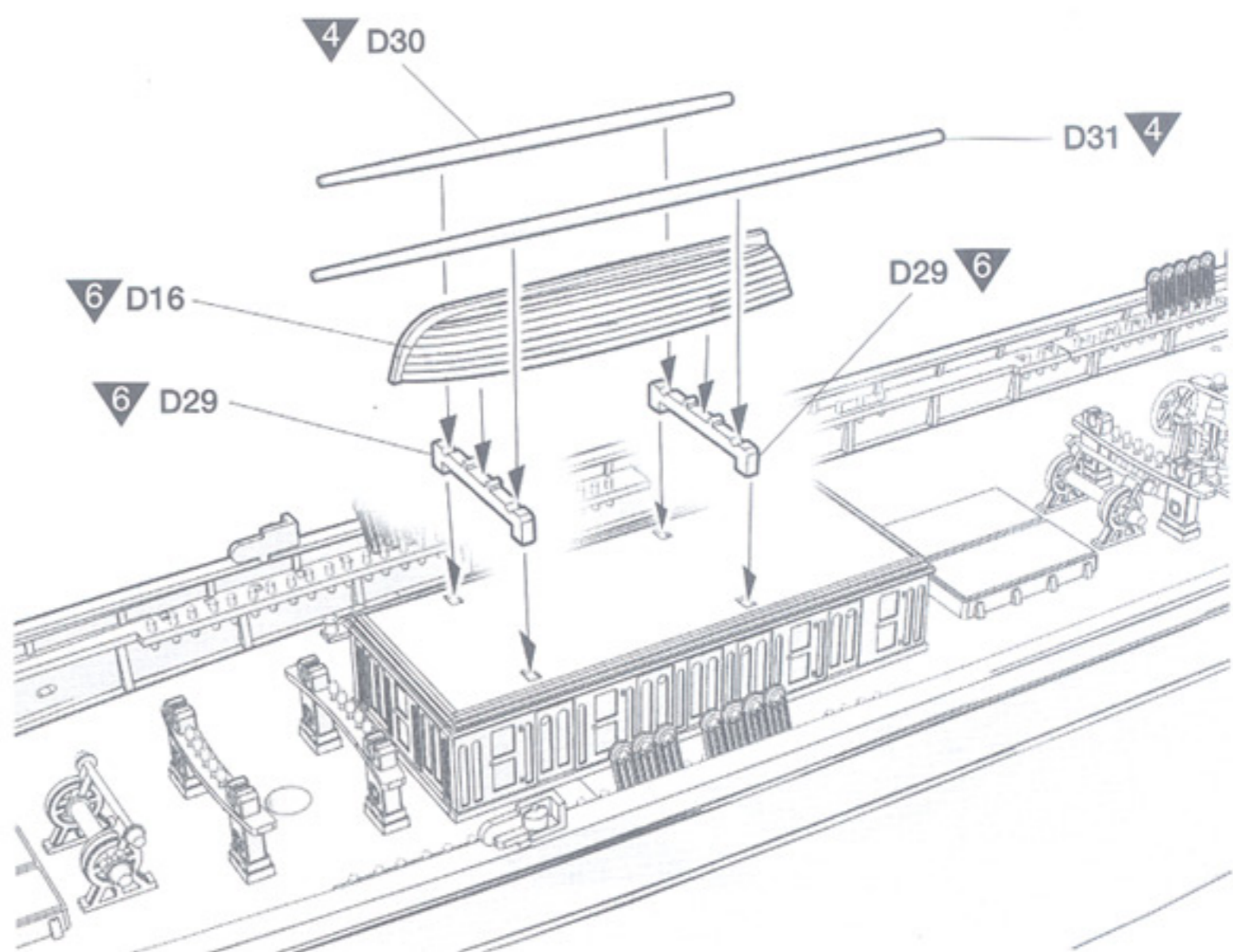
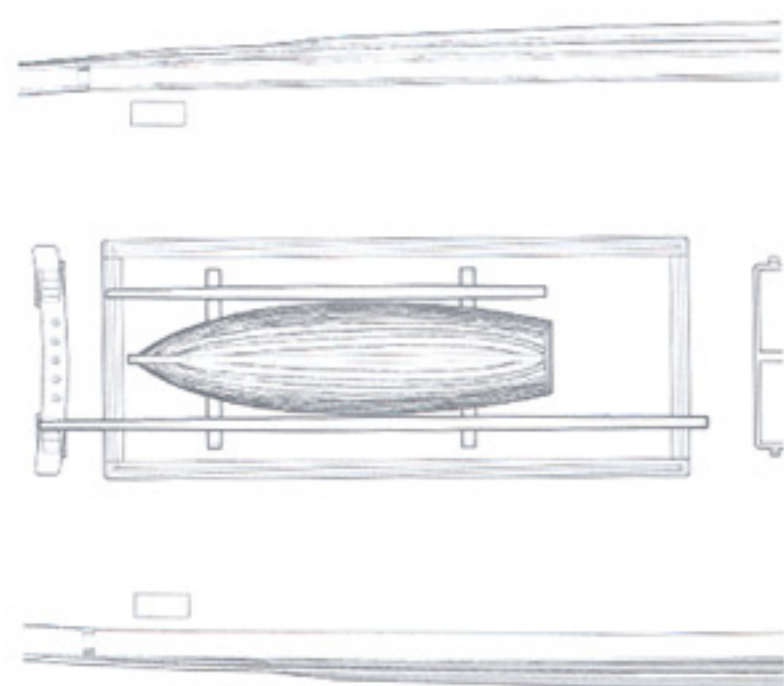

19

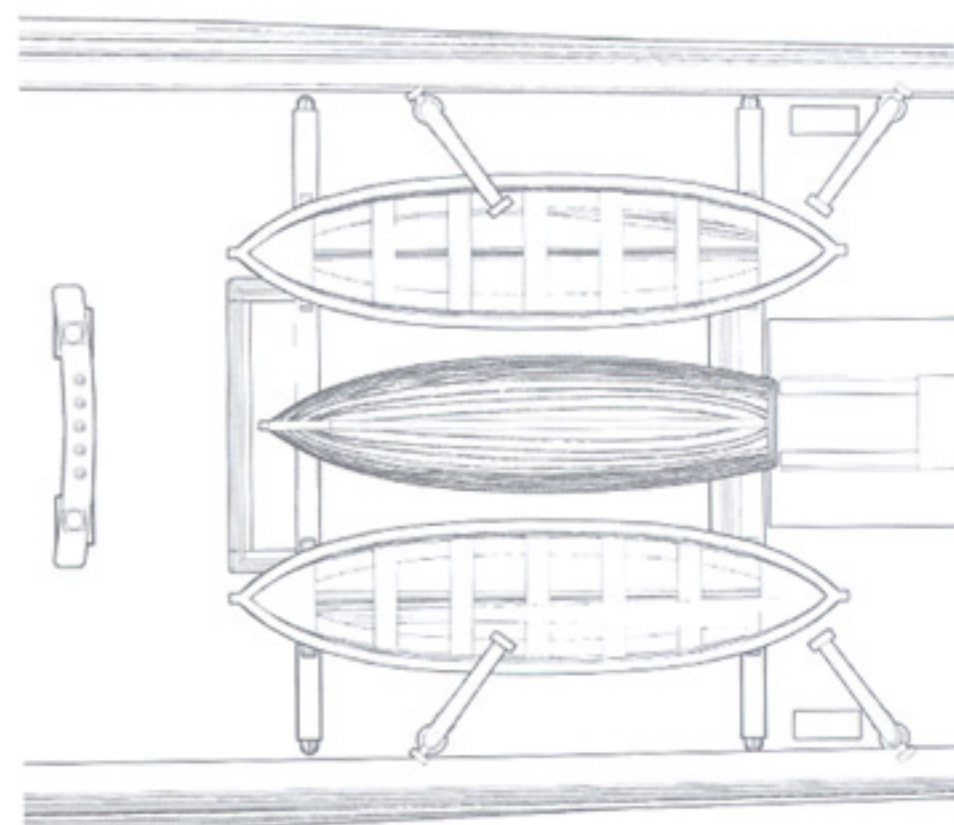
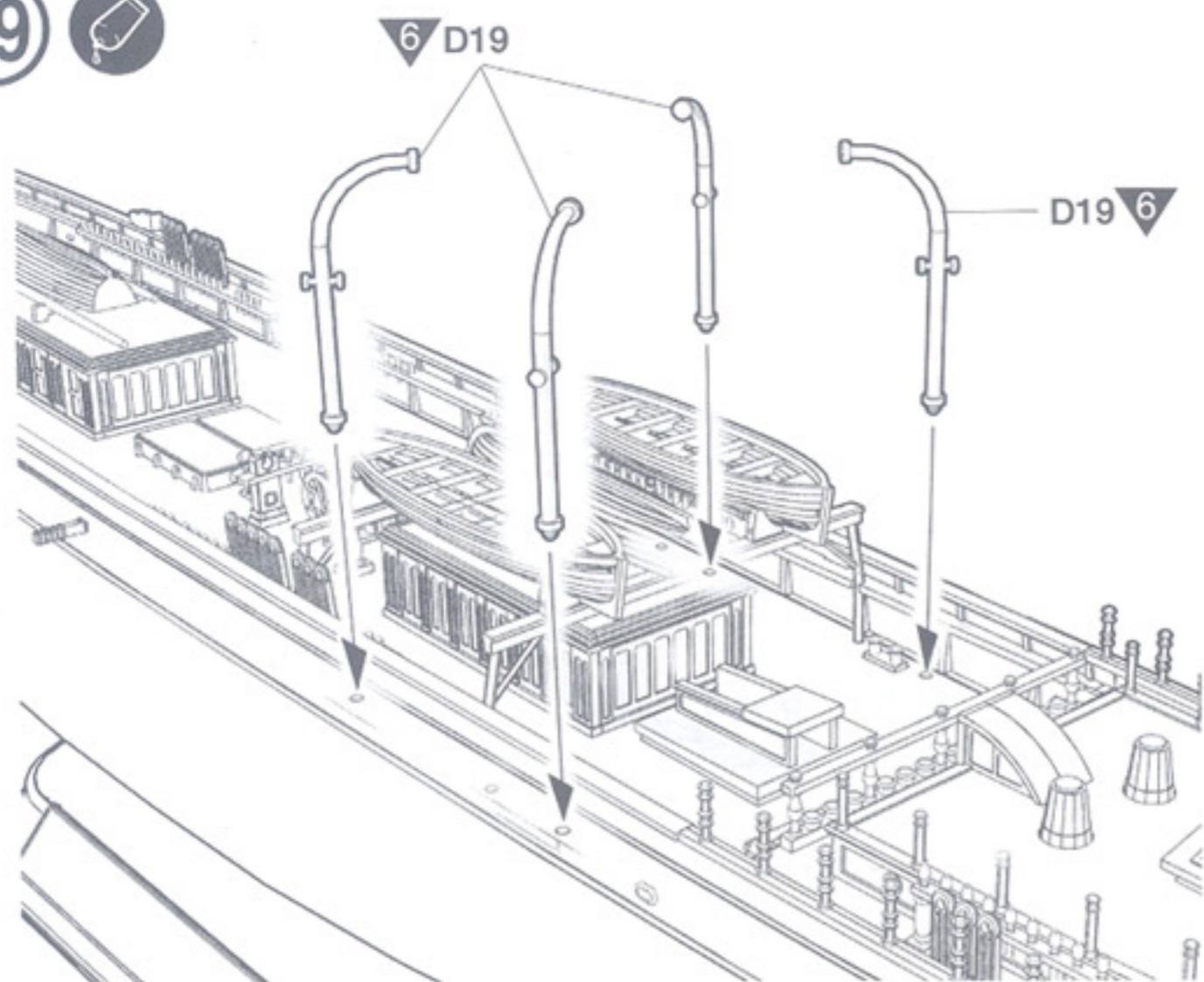

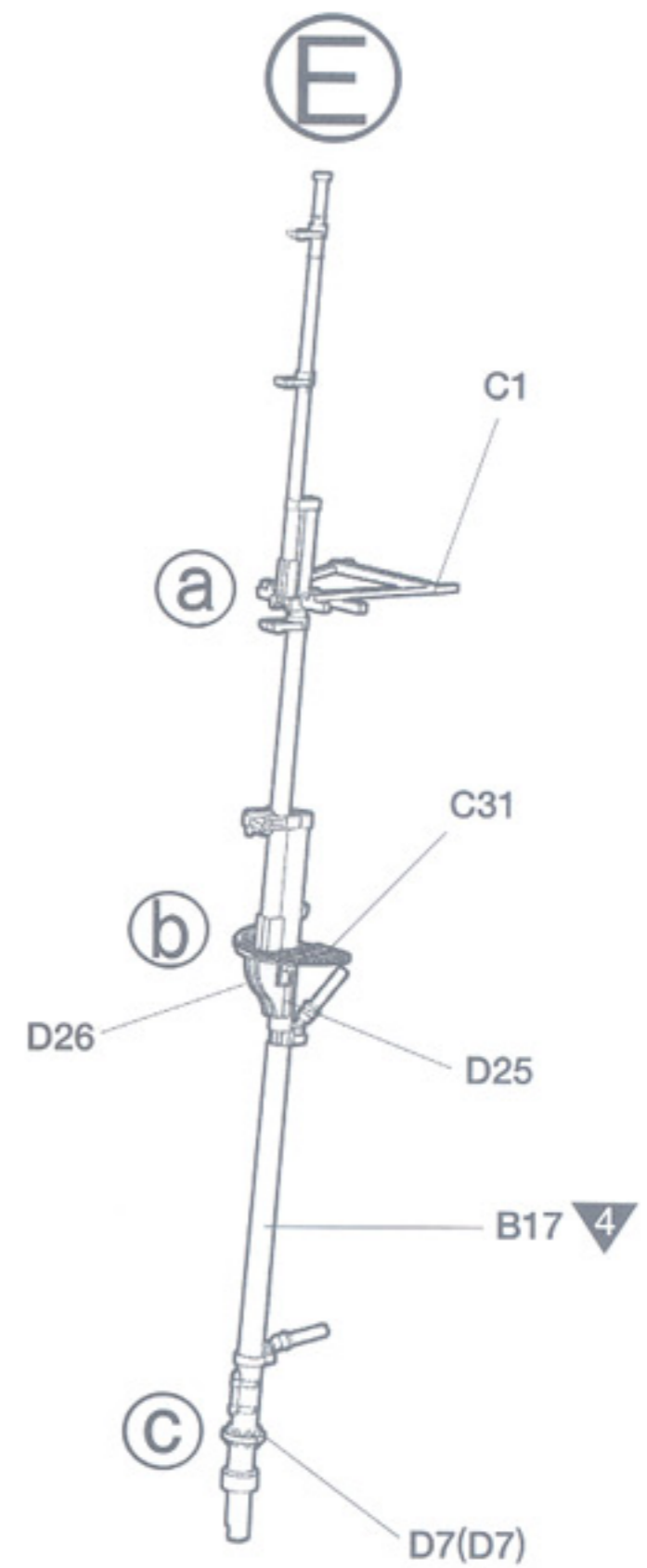
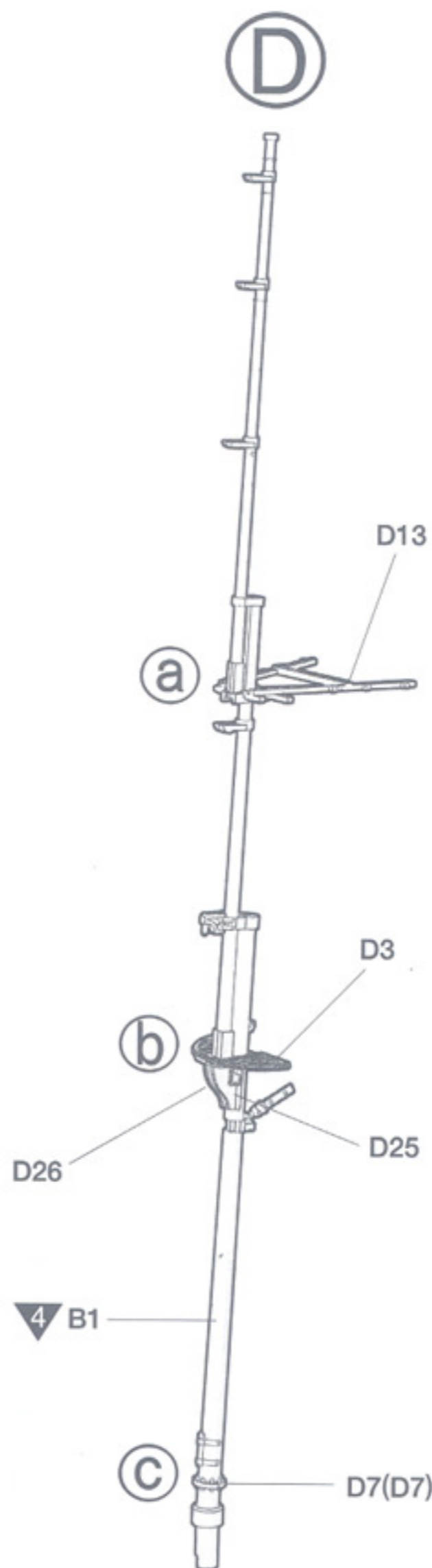
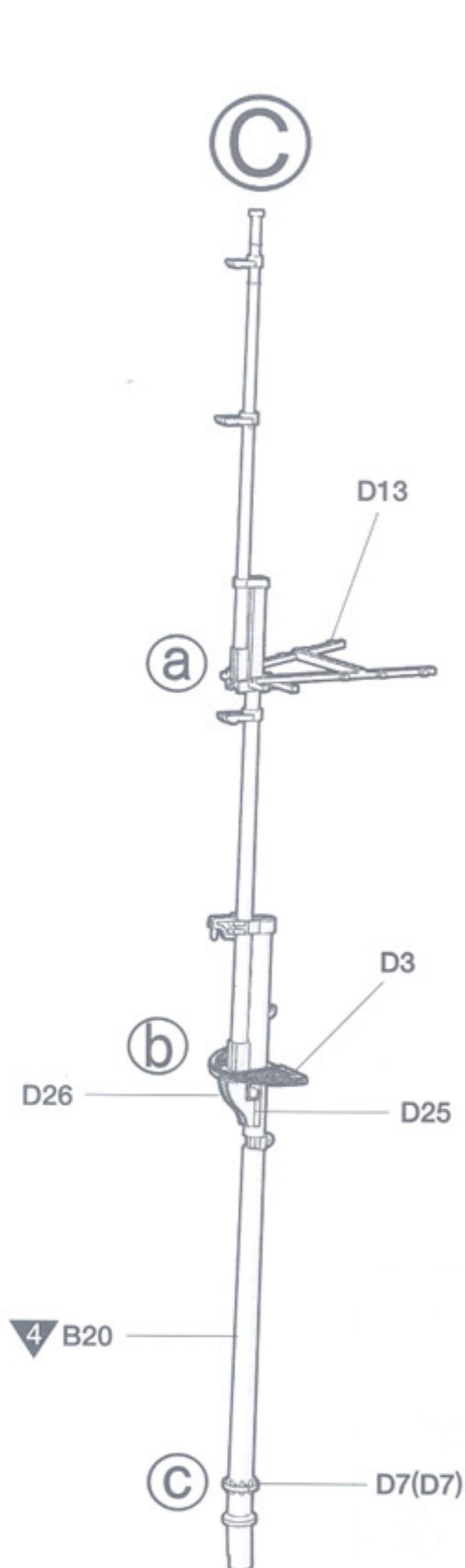
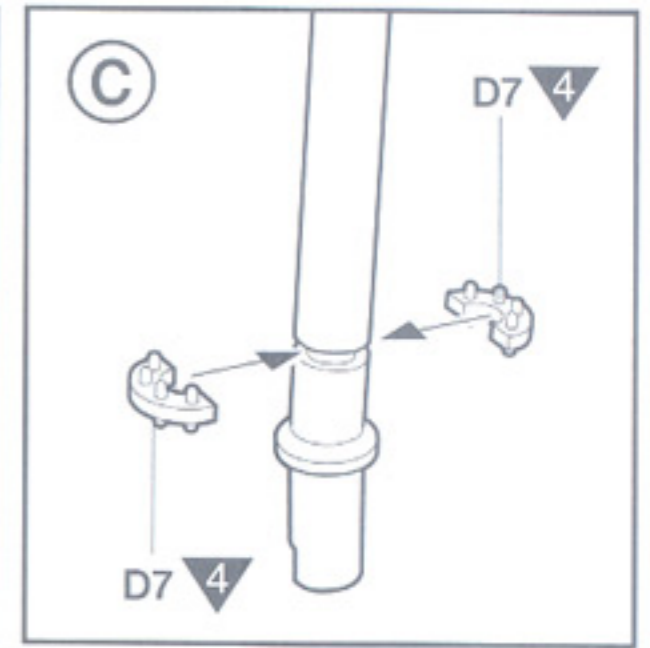
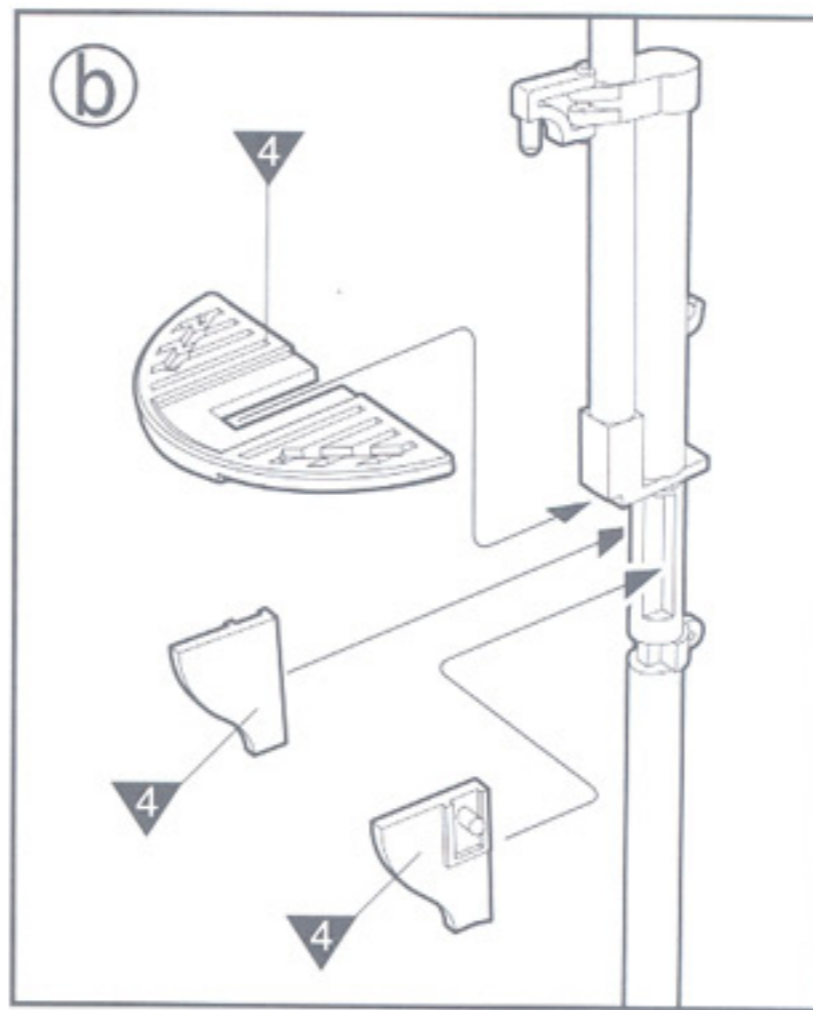
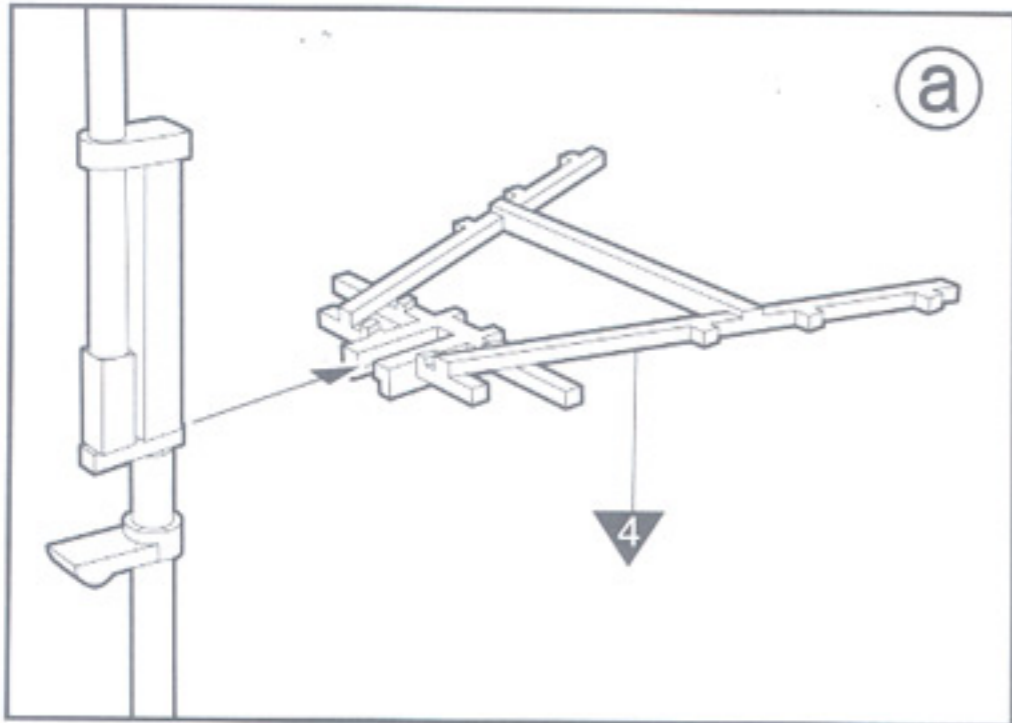

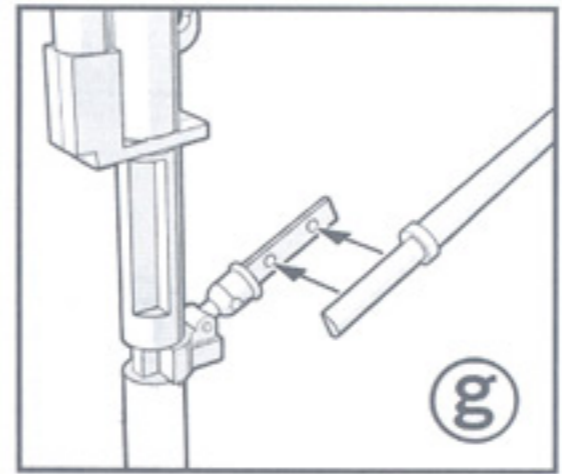
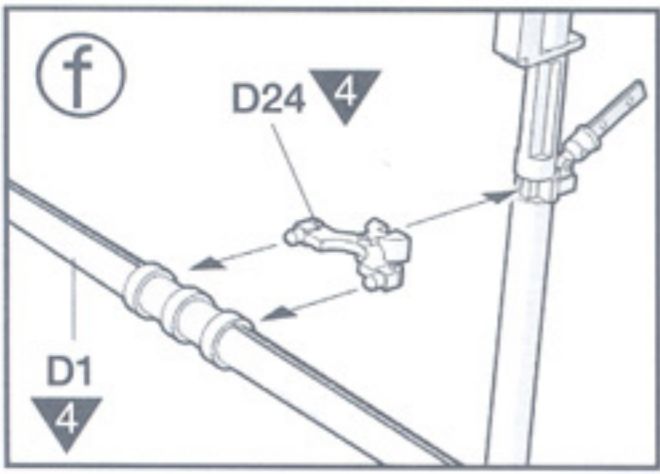
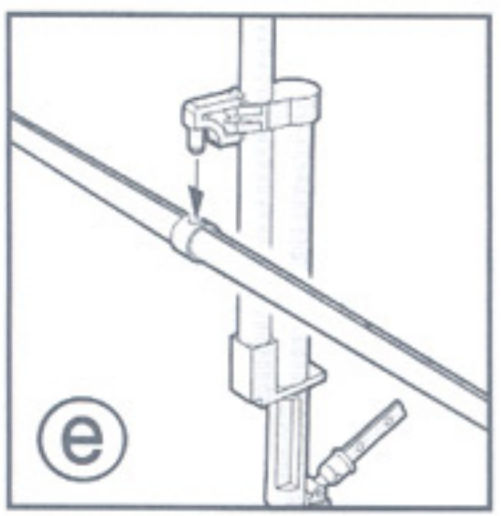
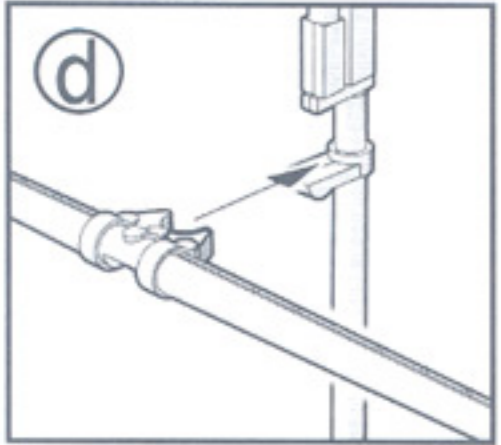
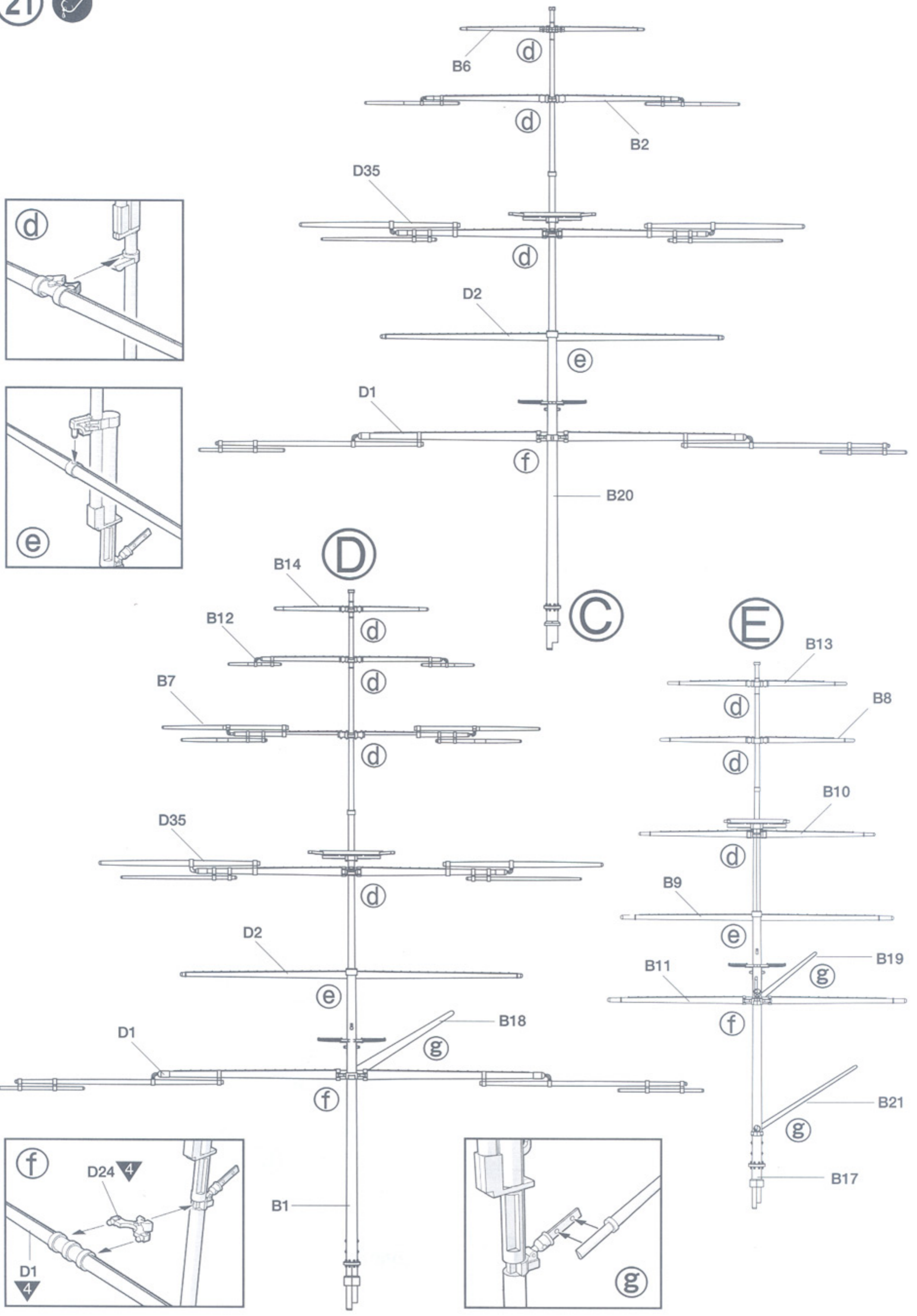

22

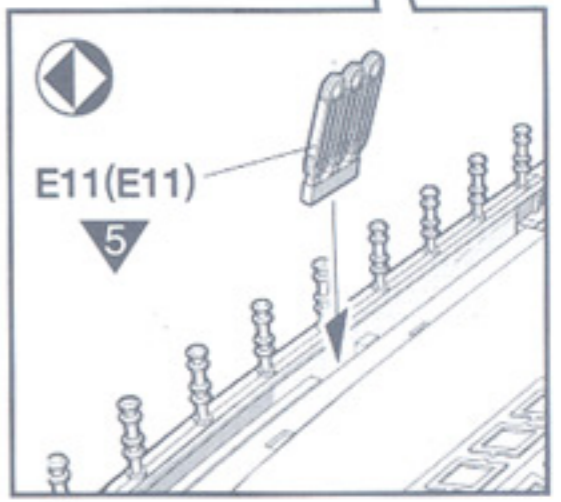
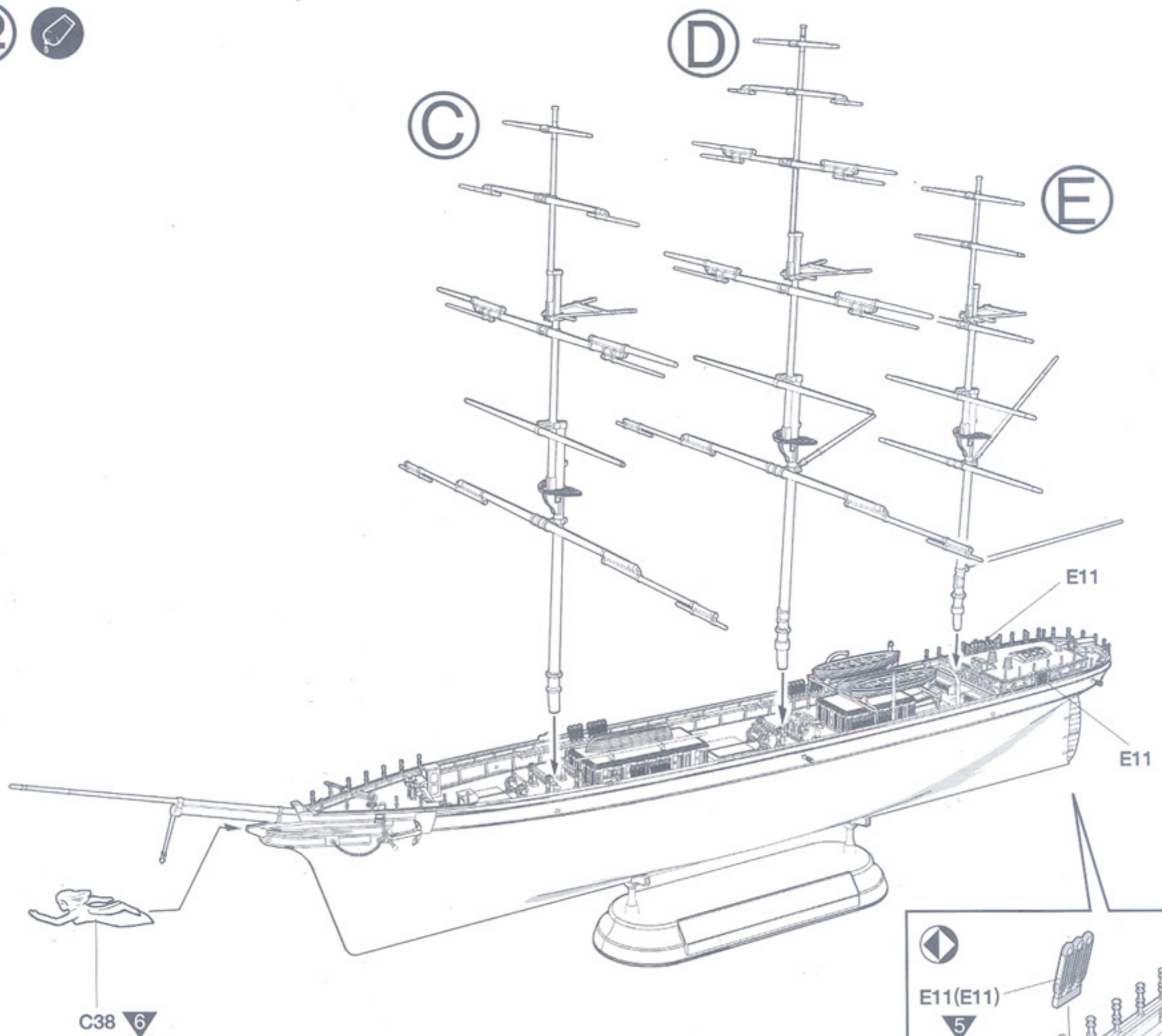

※ () is opposite number.
 ()는 반대쪽 번호 입니다.

23



※ Fit thread secure using Cyanoacrylate glue. (Not included)
 ※ 실의 정착에는 순간접착제를 사용하는 것이 편리합니다.(별매)

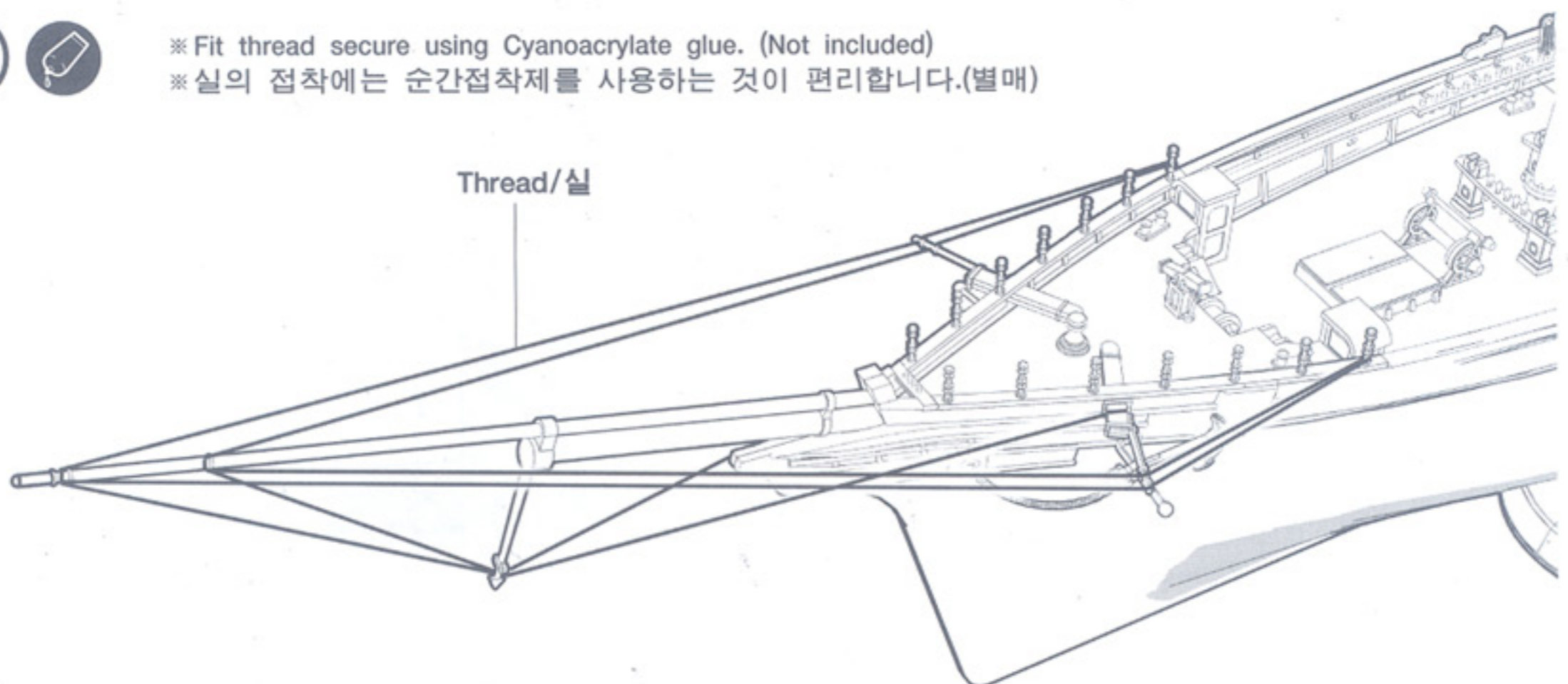



Thread/실

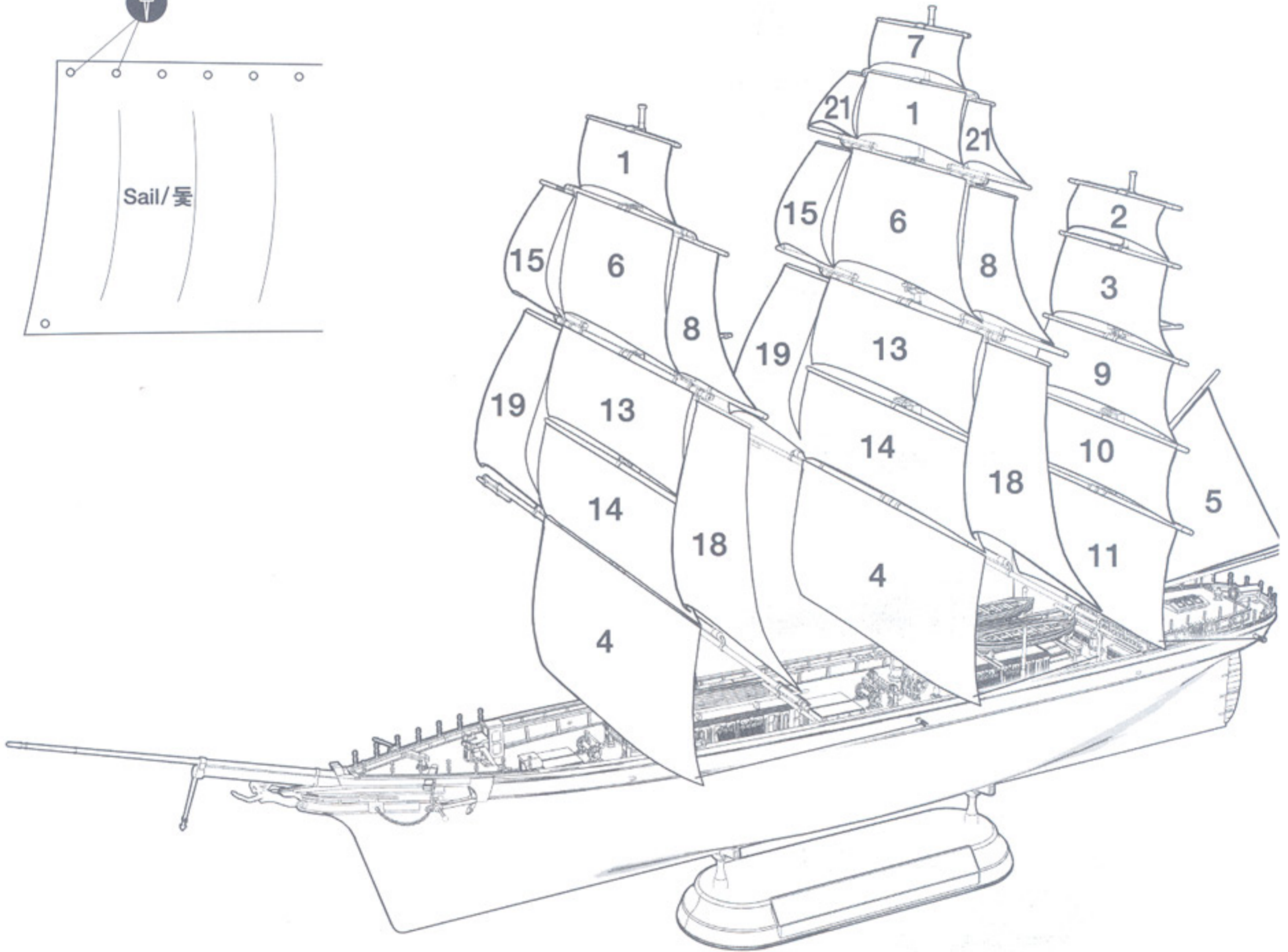
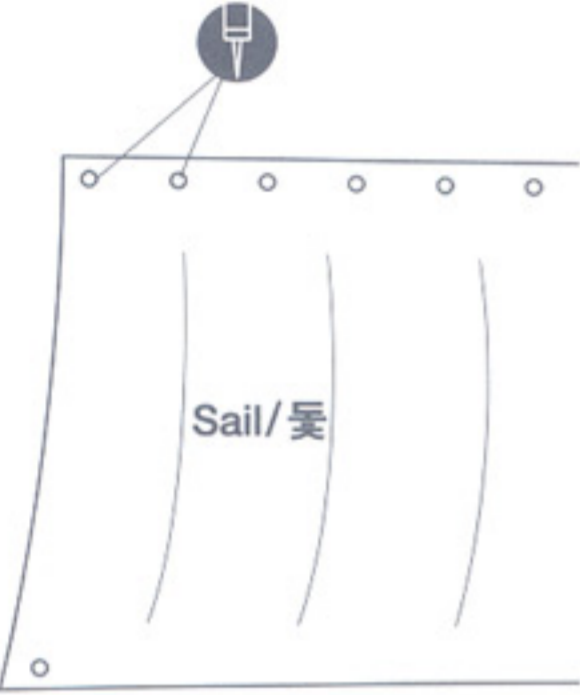
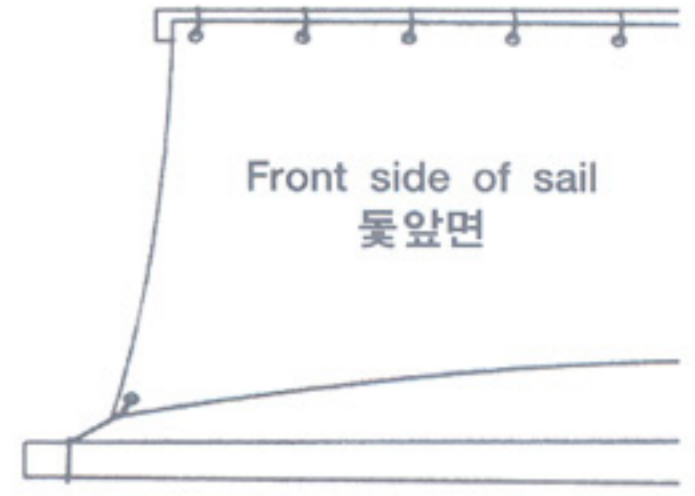
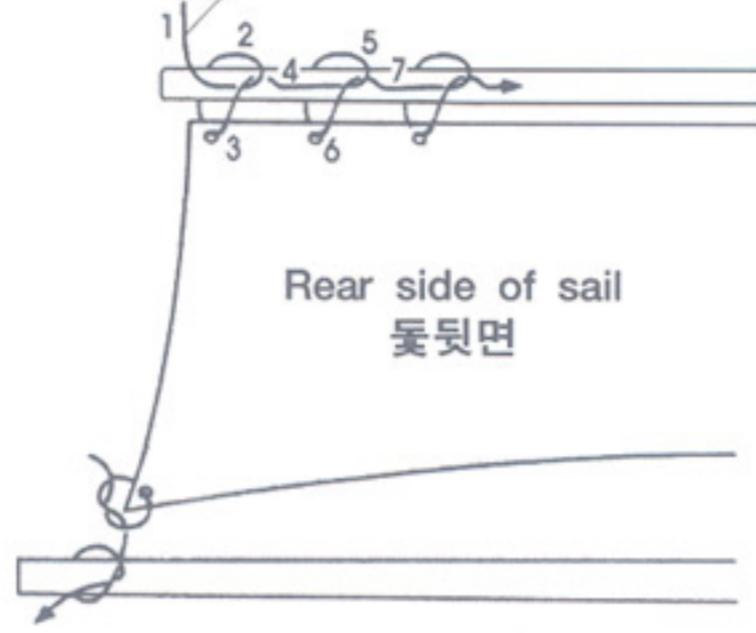
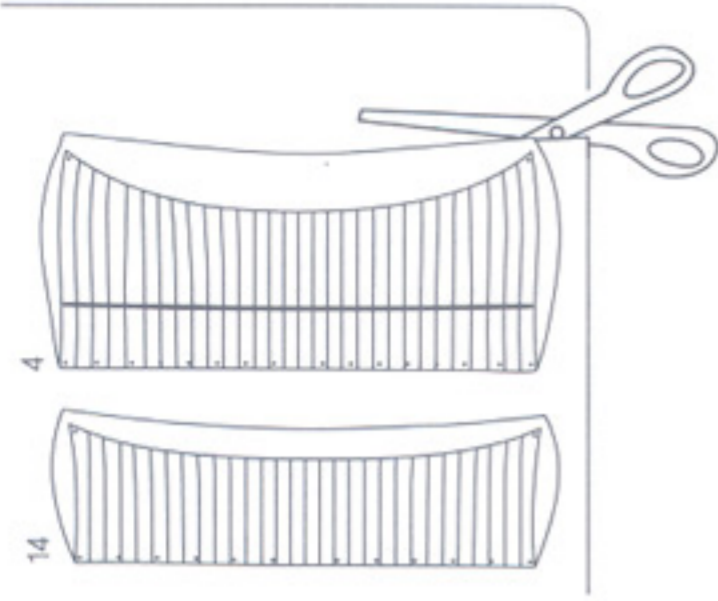

* Same type of knot will be applied for right for right side.
* 우측면도 같은 방법으로 묶는다.

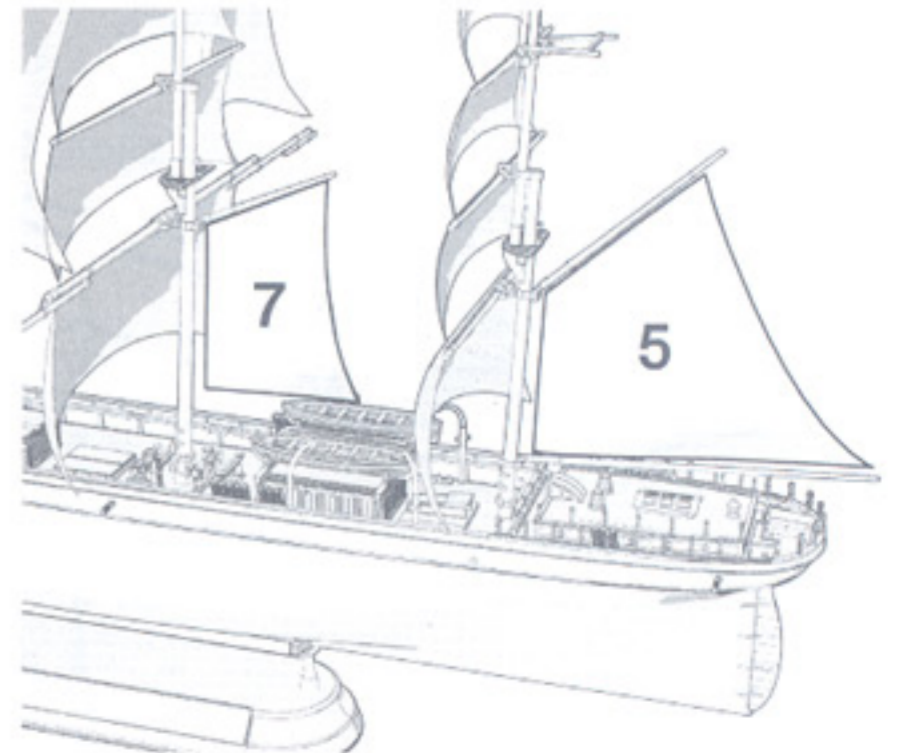

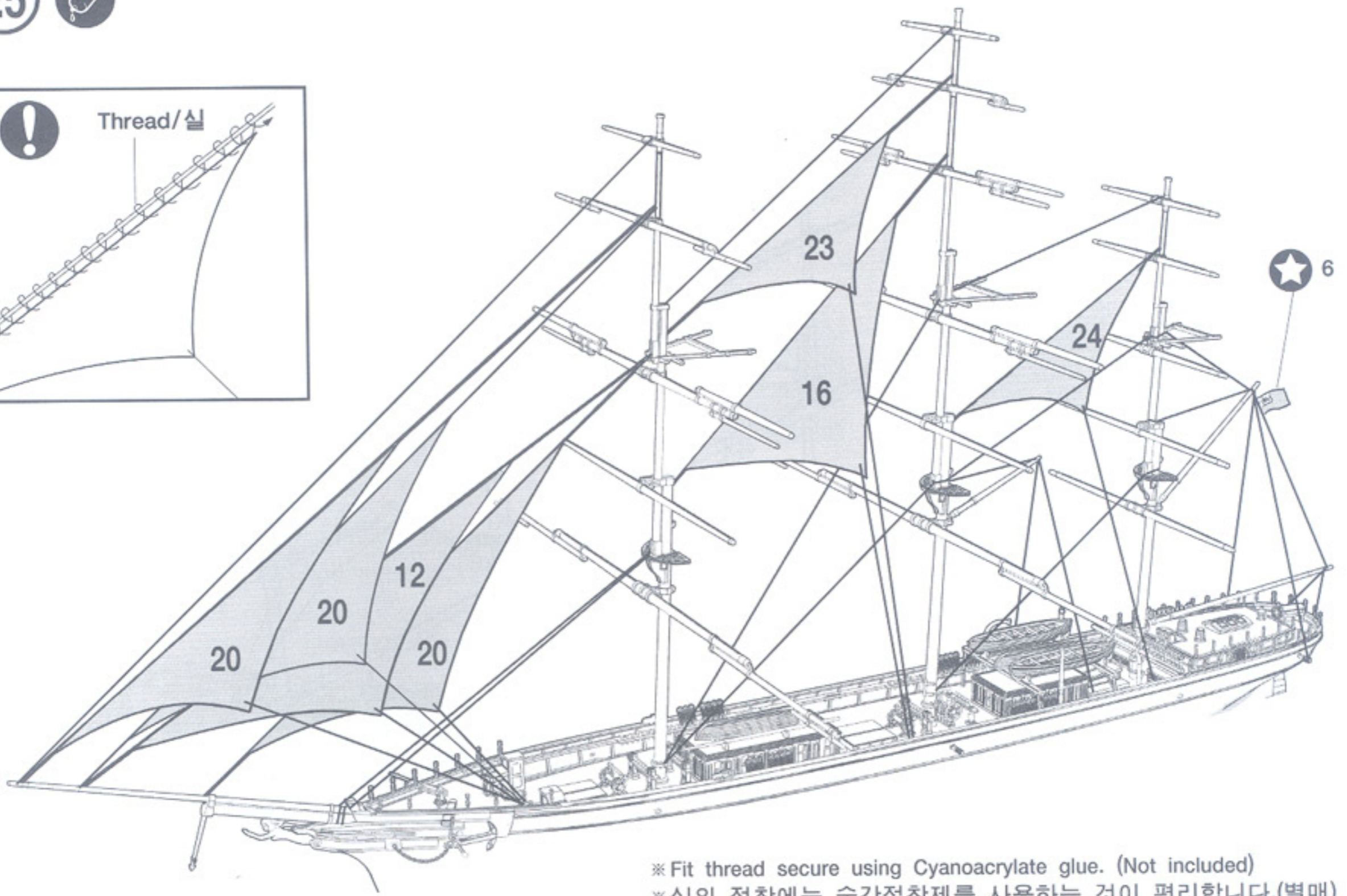
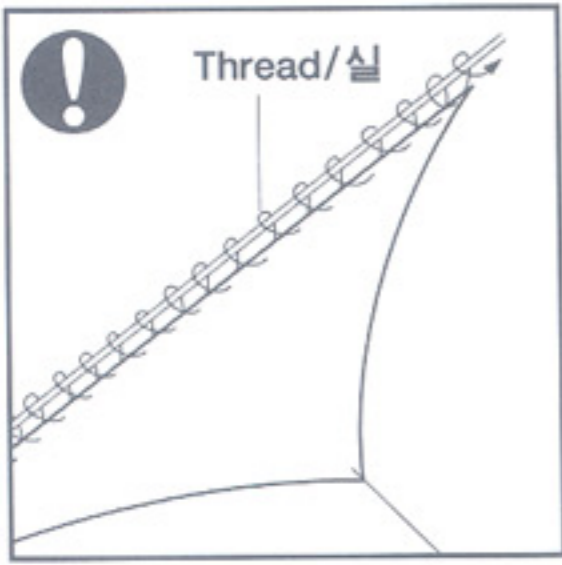

25 

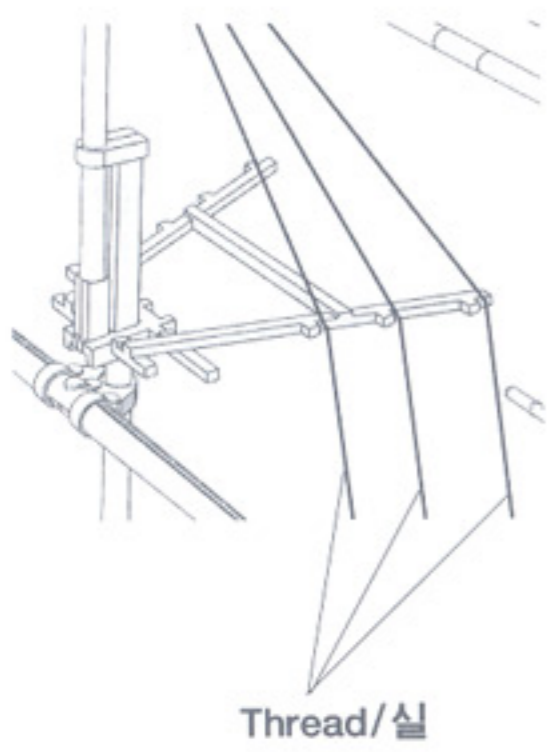

※ Fit thread secure using Cyanoacrylate glue. (Not included)
 ※ 실의 점착에는 순간접착제를 사용하는 것이 편리합니다.(별매)

26 



 ※ Same type of knot will be applied for right for right side.
 ※ 우측면도 같은 방법으로 묶는다.

27



* Same type of knot will be applied for right for right side.
* 우측면도 같은 방법으로 묶는다.

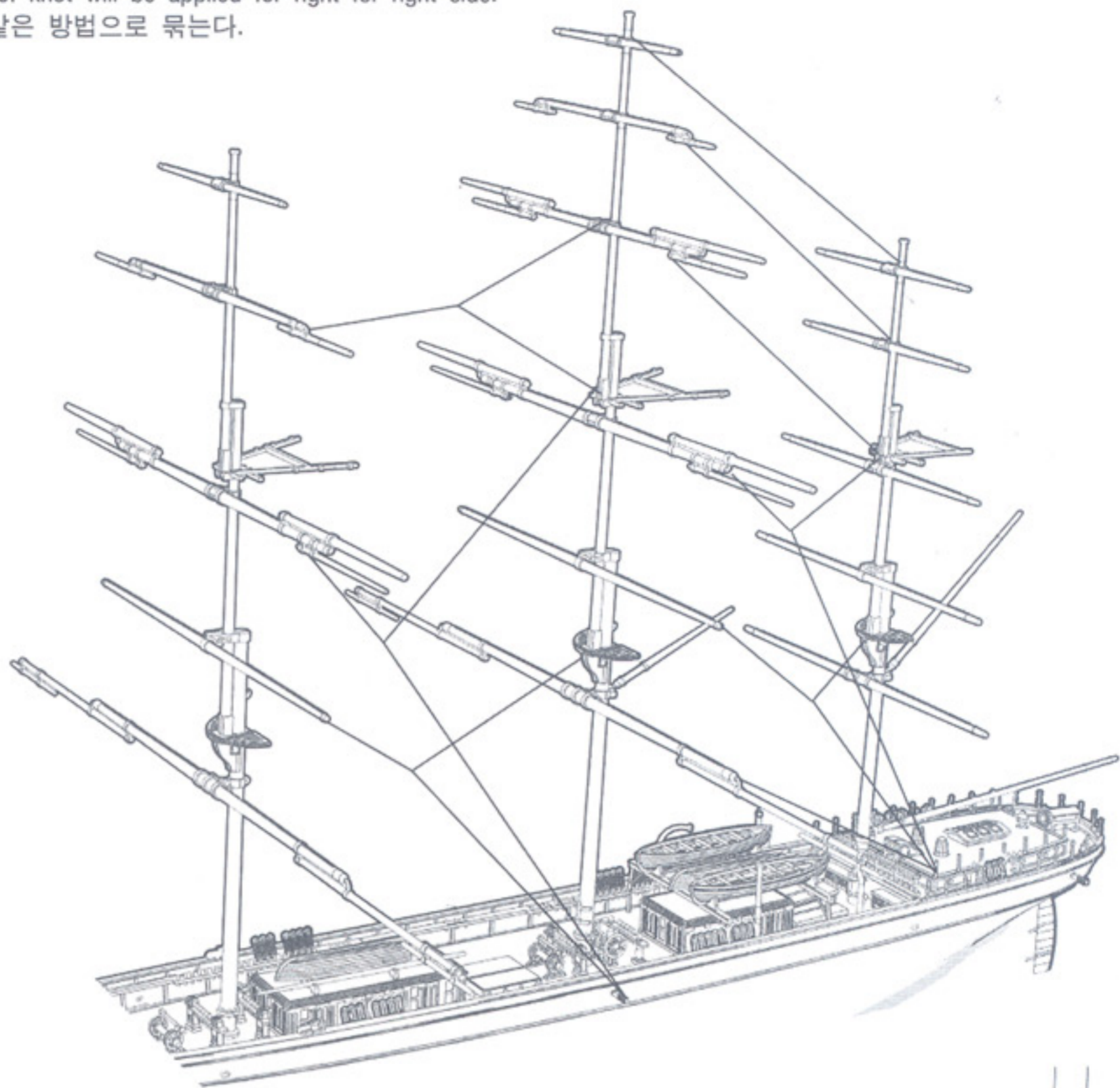

28

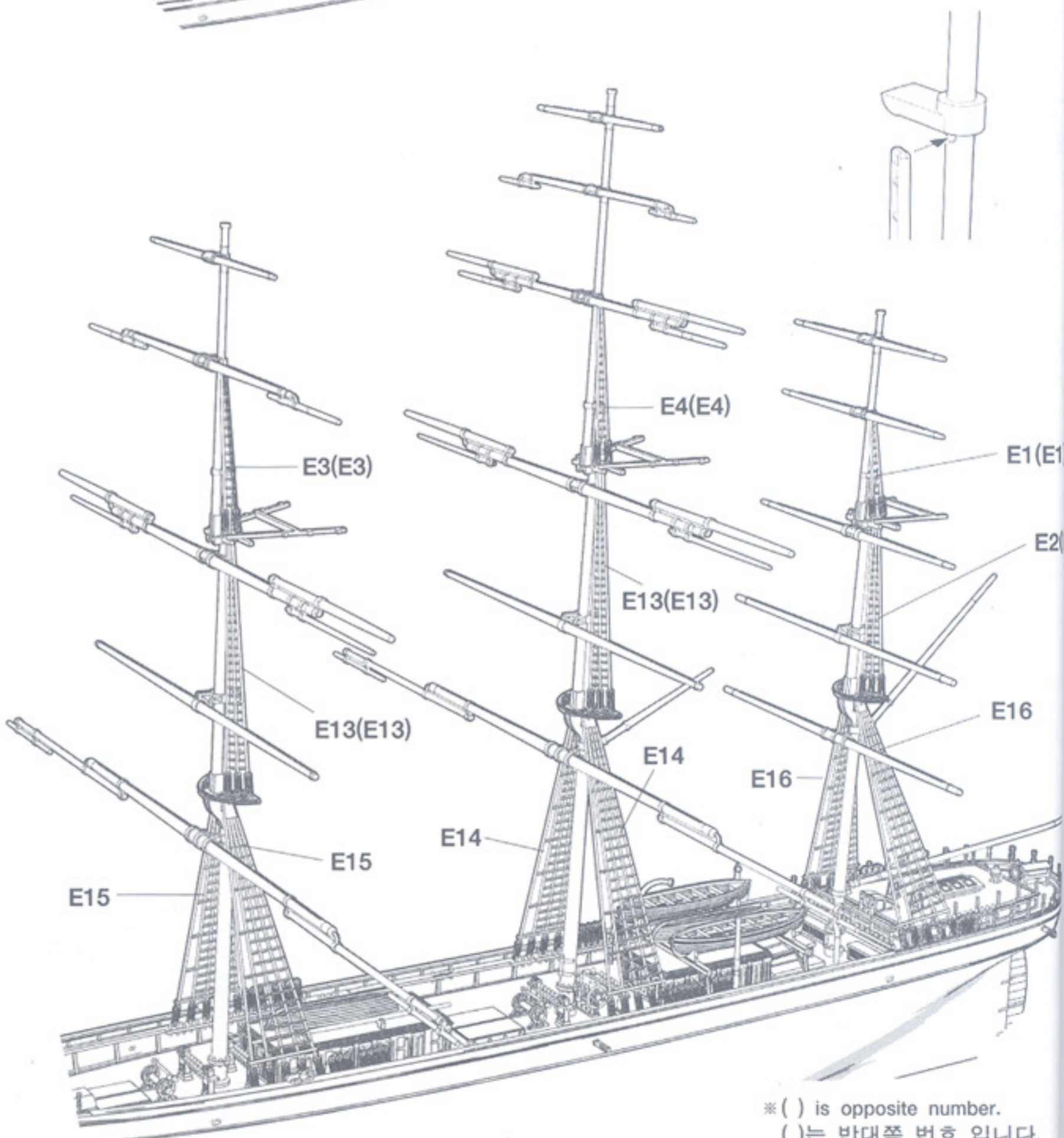
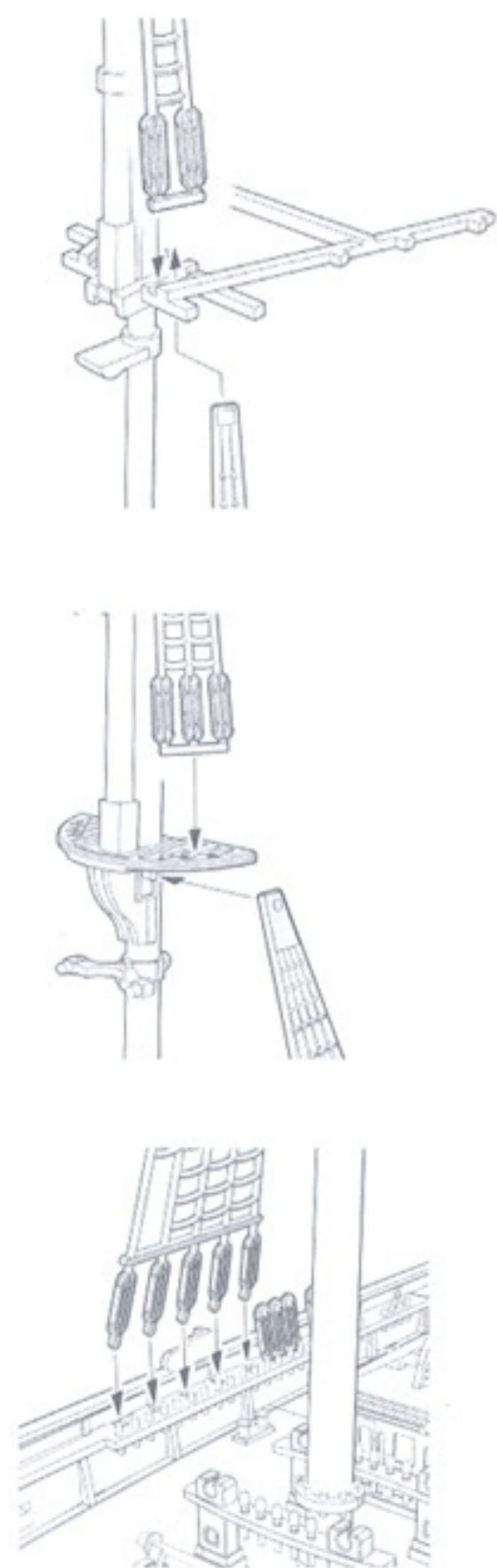

* () is opposite number.
()는 반대쪽 번호 입니다.

Parts Locating Diagram 부품도

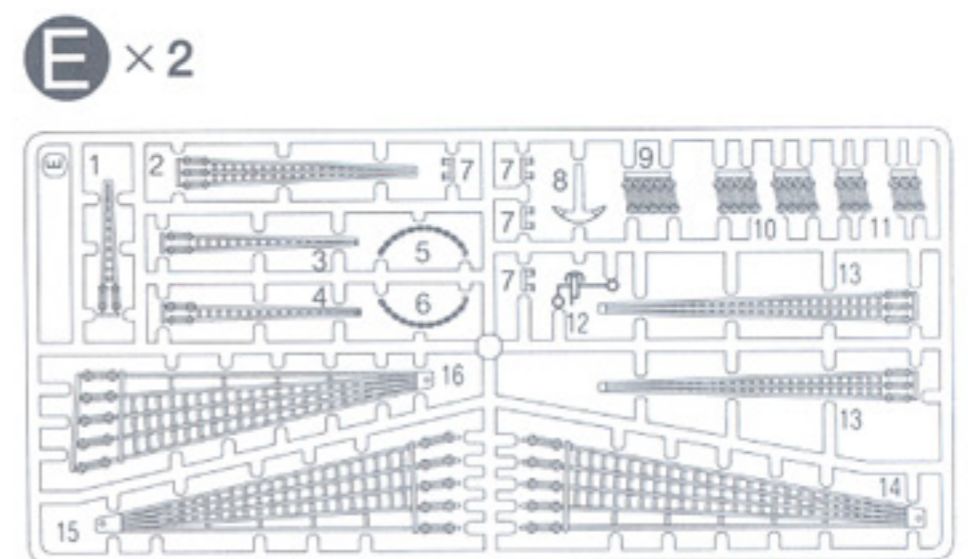
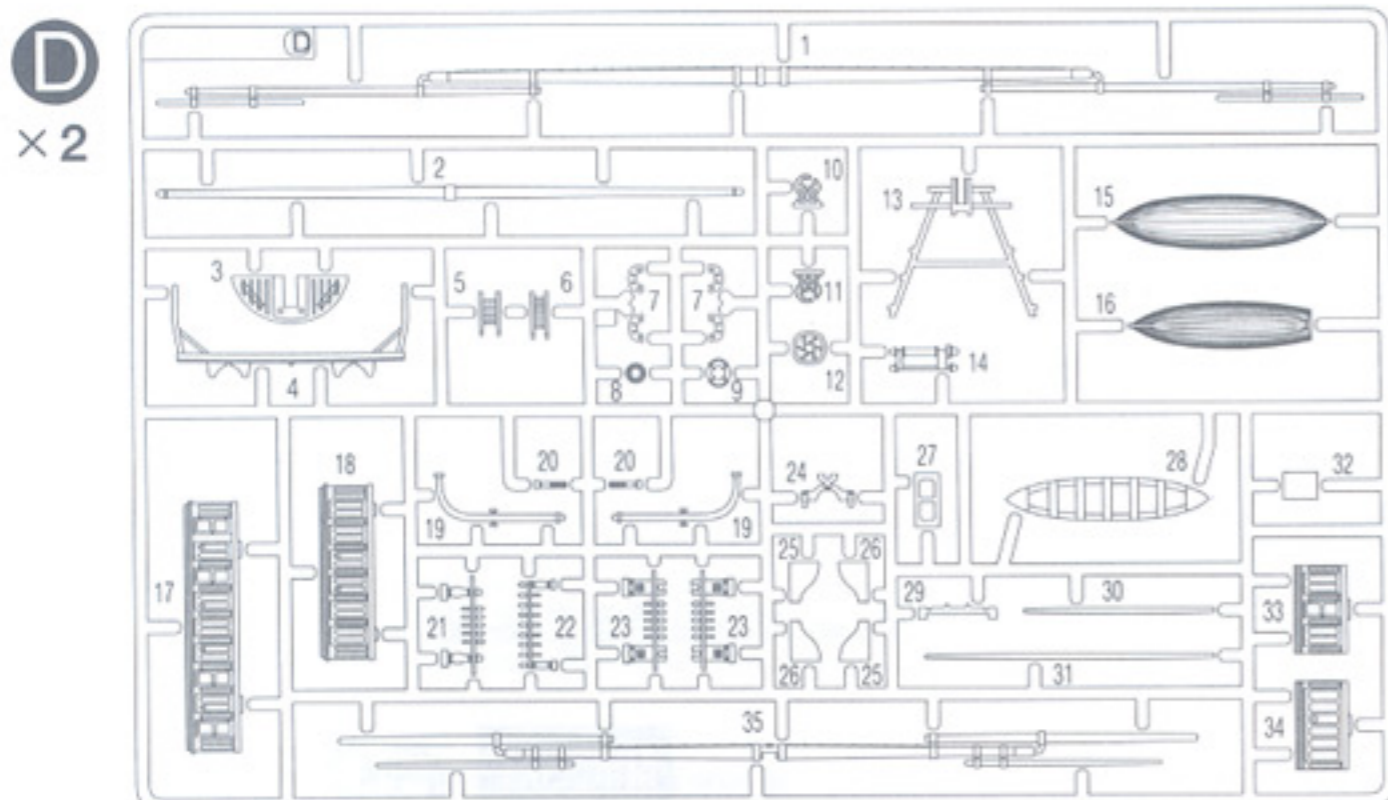
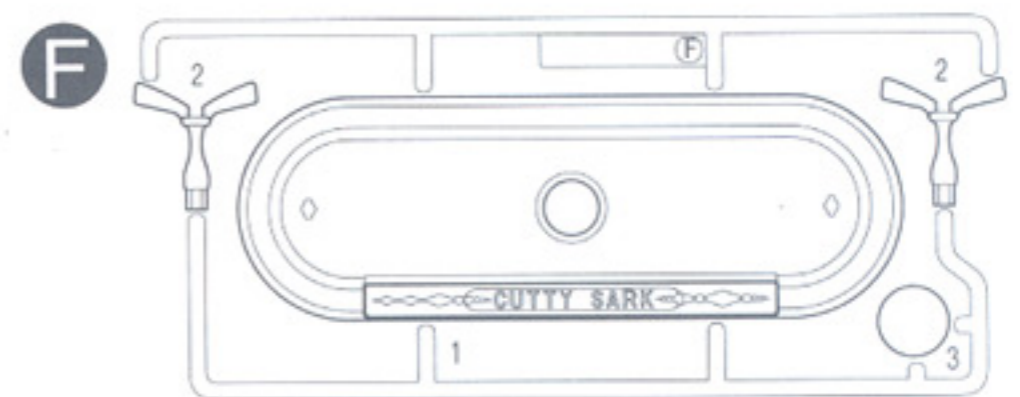
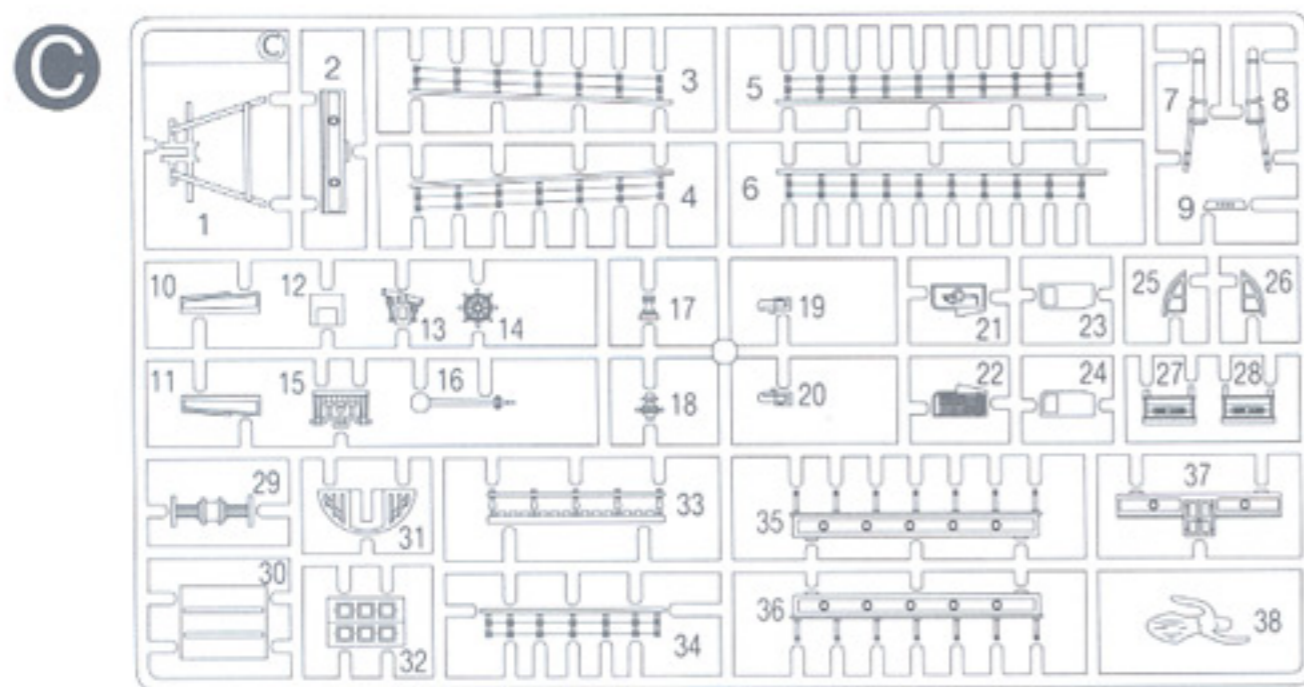
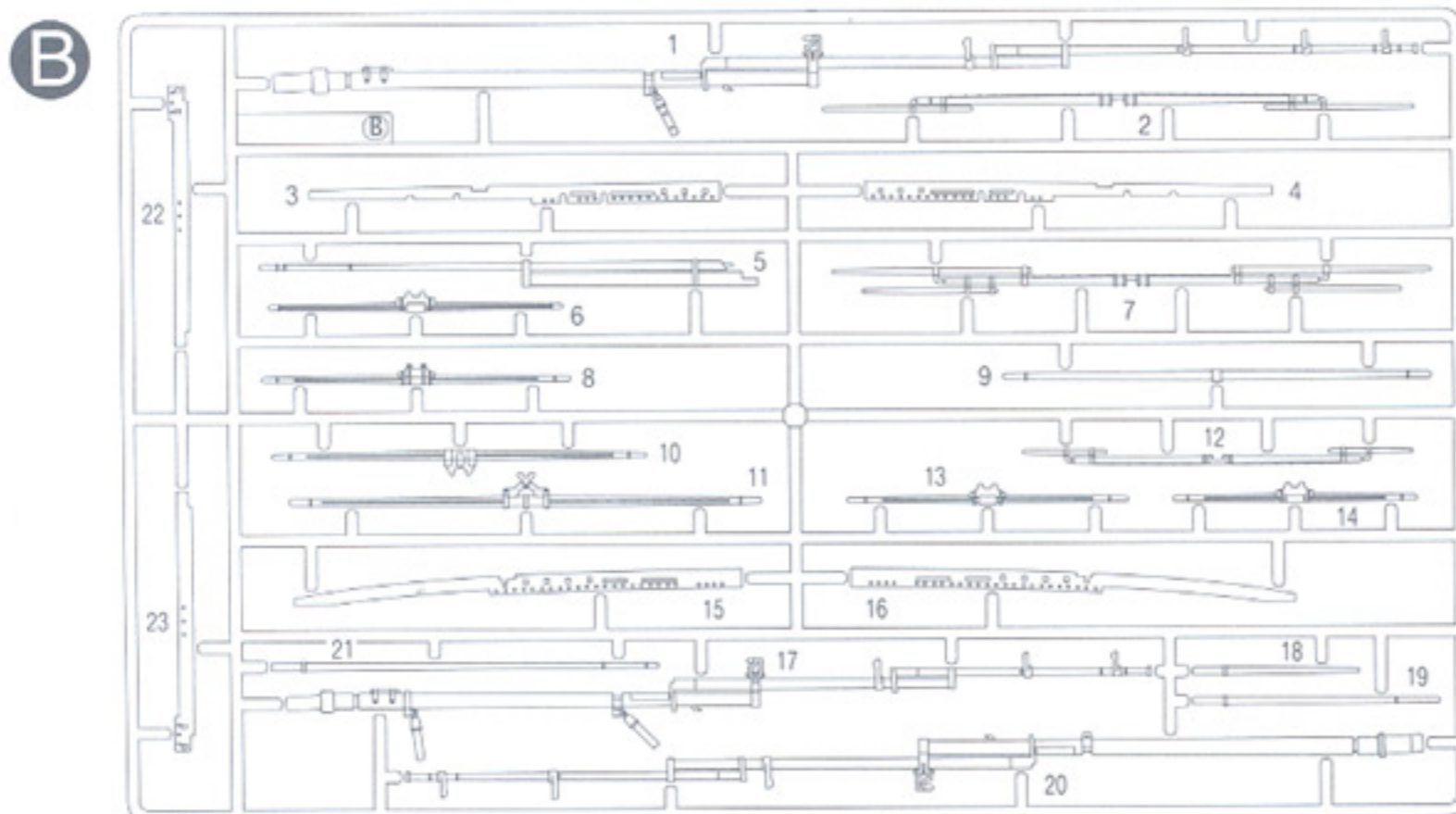
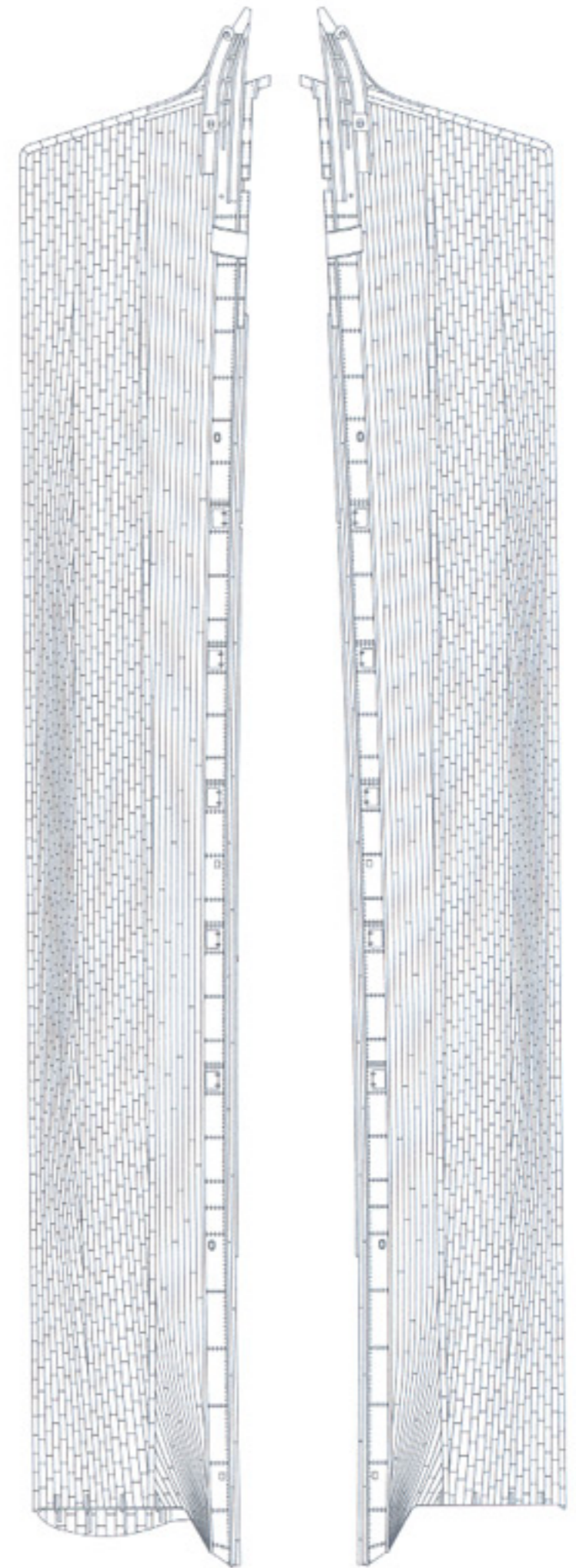
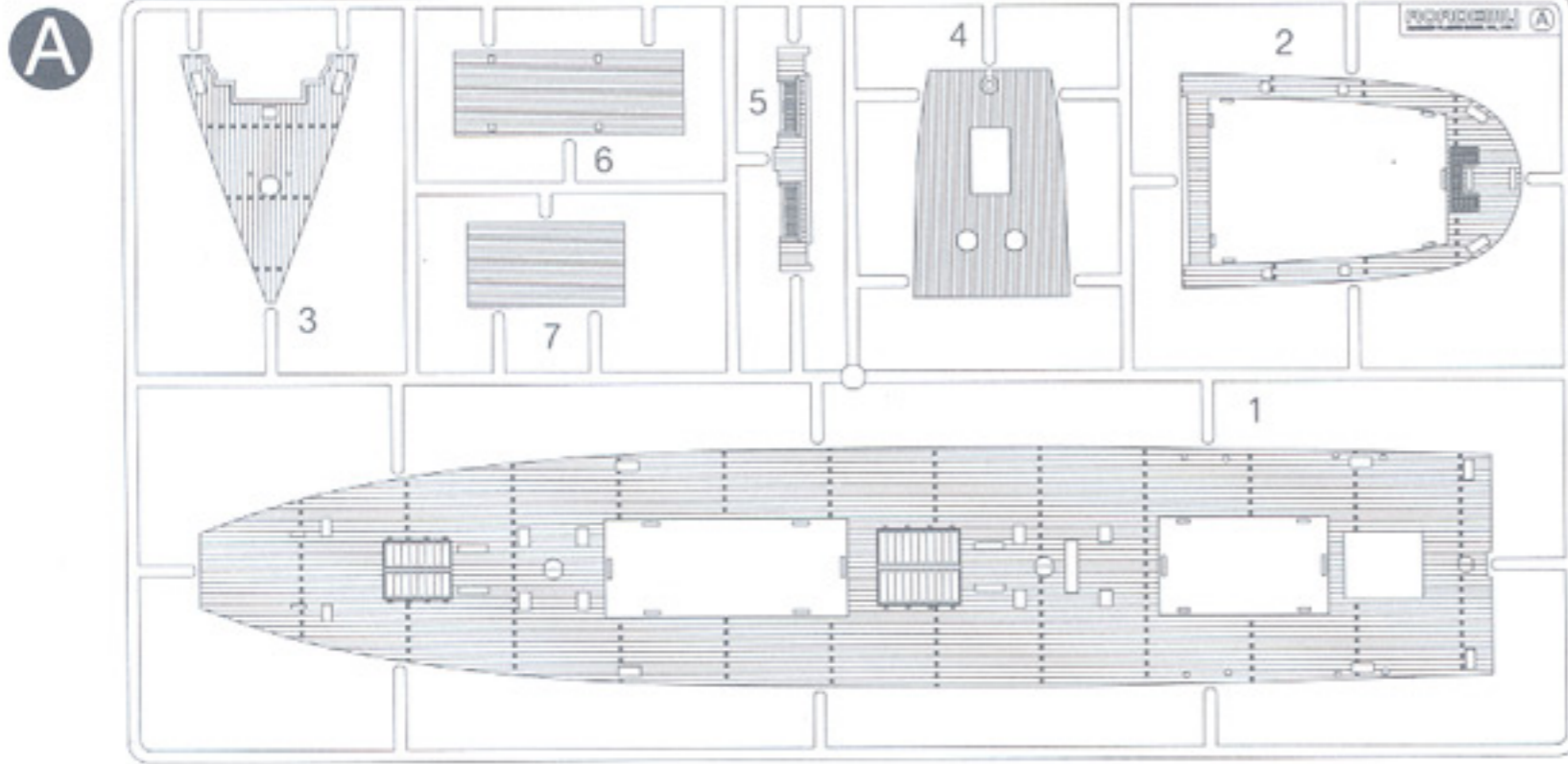

● Decal/전사지 ● Thread/실

■ UNUSED PART : D7×2, D21×1, D23×1, D25×1, D26×1, D30×1, D31×1, E5×1, E6×1
불필요 부품

Parts Locating Diagram 부품도

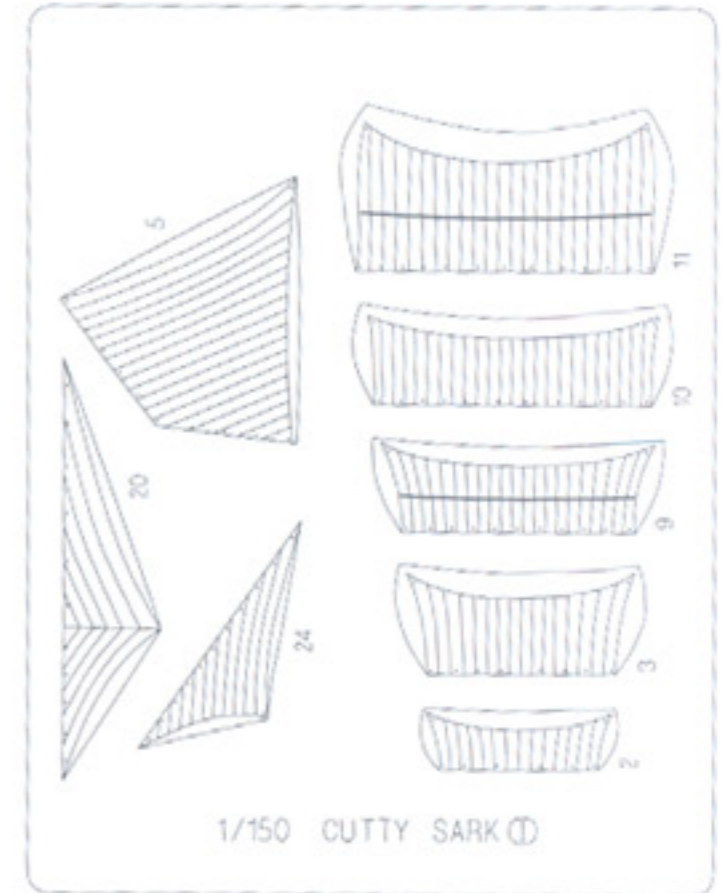
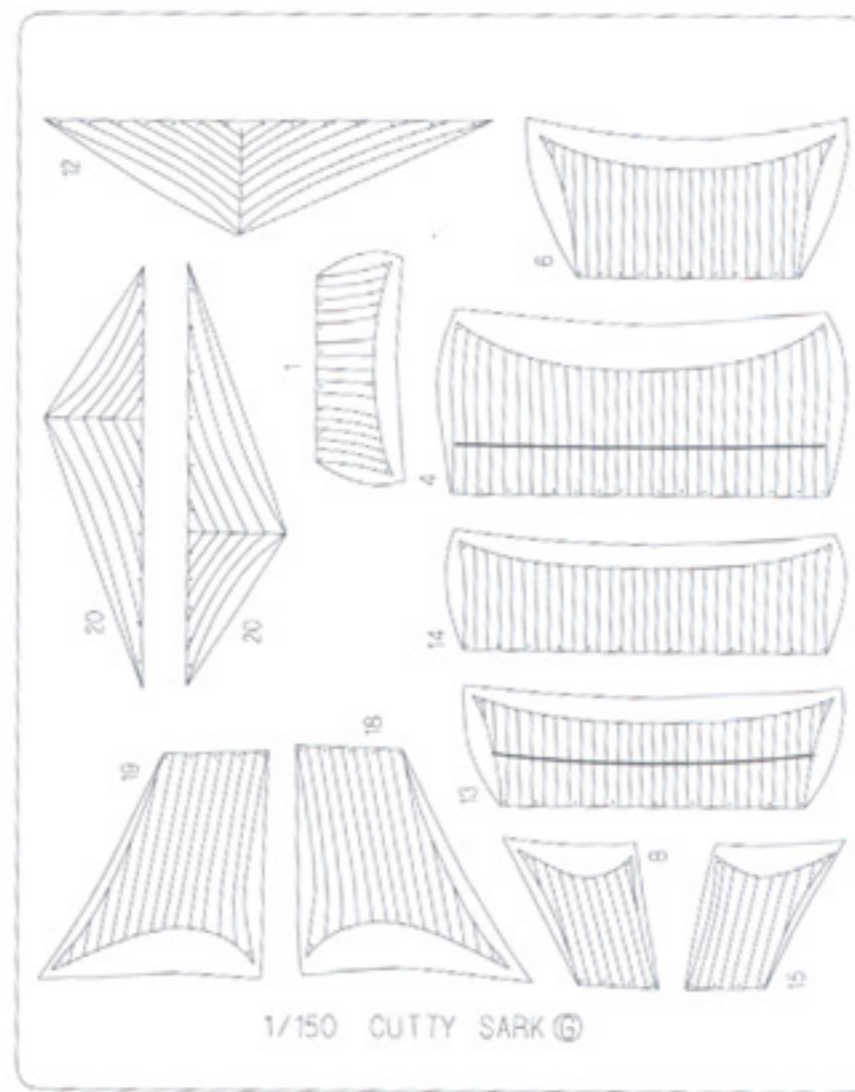
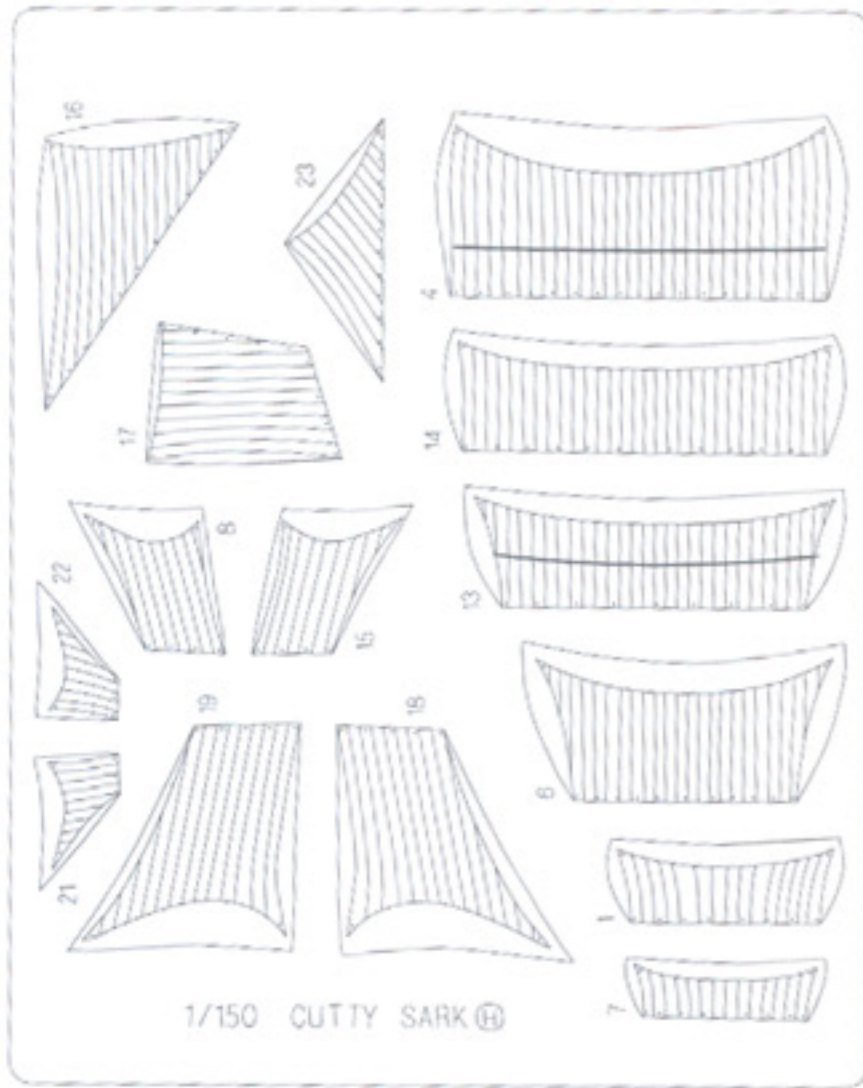

		GSI CREOS		LIFE COLOR	HUMBROL	TESTOR/MODEL MASTER		
		AQUEOUS HOBBY COLOR	Mr. COLOR			ENAMEL	ACRYL	
1	RED	H<3>	3	LC56	19	1103		유광빨강
2	GOLD	H<9>	9	LC75	16	1744	4671	금색
3	TAN	H<44>	27	LC21	61		4230	탄 (갑판색)
4	WOOD BROWN	H<37>	43	LIA085	186	1701	4707	우드 브라운
5	FLAT BLACK	H<12>	33	LC02	33	1749	4768	유광검정색
6	WHITE	H<1>	1	LC51	22	1745	4696	유광흰색
7	STEEL	H<18>	28	LC76	53	1780	4679	흑철색
8	COPPER	H<10>	10	LC78	12	1151	4217	카퍼(구리색)

Painting & Decal placement 색칠 및 전사지 붙이기

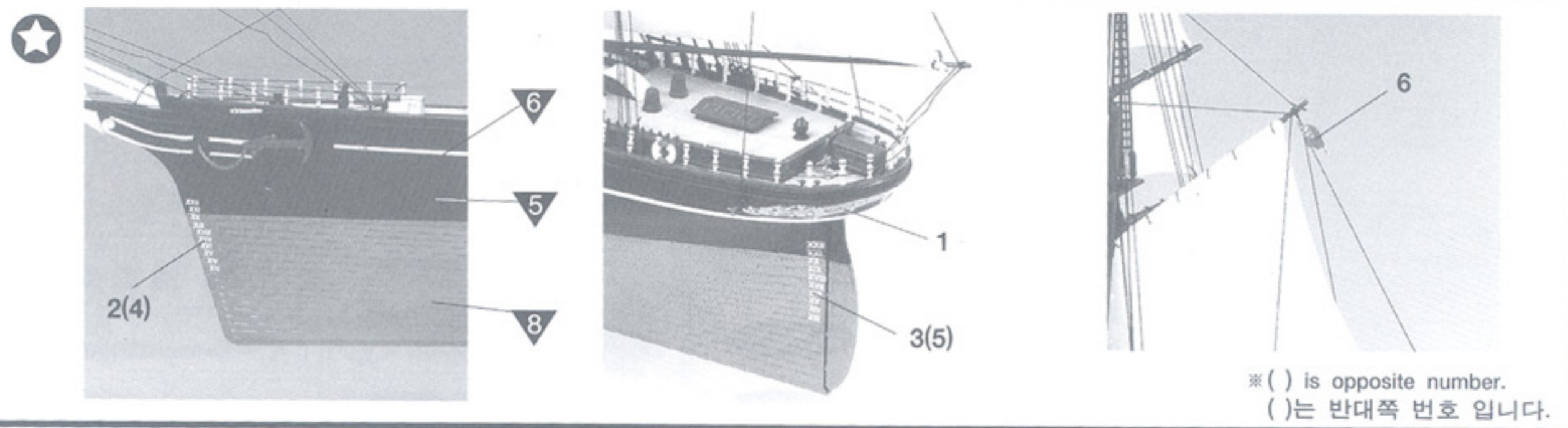

- 총판점 : 강남아카데미:485-6884, 강북아카데미:762-0980, 강서아카데미:2678-7988, 경기아카데미:(031)388-9815, 경남아카데미(창원):(055)298-6940, 대구아카데미:(053)744-9293, 대구 R/C:(053)741-6326, 서면아카데미:(051)816-9773, 서울아카데미:907-0940, 아티(구리):(031)527-8801, 양재아카데미:575-9997, 용산아카데미:796-1214, 용산 R/C:711-0922
- 매 장 : 삼선교:742-9293, 아셈하비:6002-6293, 하비관:701-4293 ● A/S센터 : 본사:908-7000(교환 147, 148), 동대문:745-9293, 천호동:485-6884
- 고객상담문의 : 080-969-7000 ● 본사주소 및 전화번호 : 서울시 강북구 수유2동 273-64 ☎908-7000
- 홈페이지 : <http://www.academy.co.kr>